



建筑气流模拟及应用

高乃平

gaonaiping@tongji.edu.cn

机械与能源工程学院

同济大学



目录

1. 气流模拟简介
2. 人工环境领域CFD模拟的特殊问题
3. 模拟结果的质量控制
4. 案例介绍
5. 总结

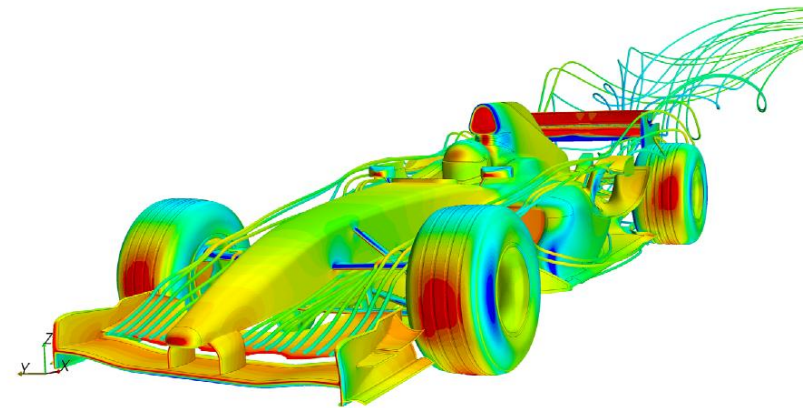

气流模拟简介

射流分析(jet calculation)

$$\frac{V_m}{V_0} = K \frac{\sqrt{H_0}}{x} K_n$$

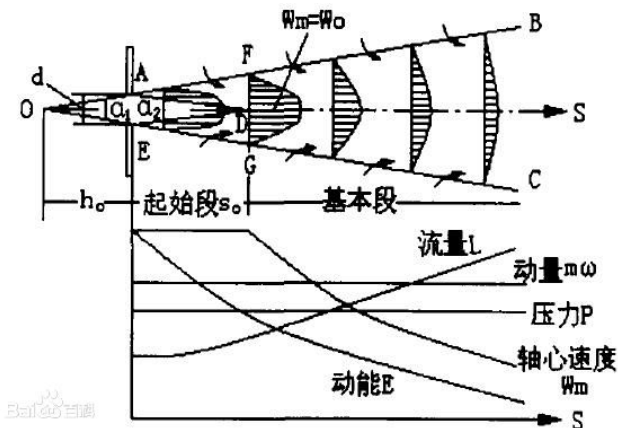

多区模拟 (multi-zone model)

$$p + \rho gh + \frac{1}{2} \rho v^2 = Const$$

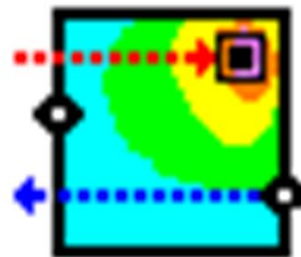

NIST Multi-zone modeling

计算流体力学 (computational fluid dynamics)

$$\frac{\partial(\rho\phi)}{\partial t} + div(\rho\phi\vec{u}) = div(\Gamma grad\phi) + S_\phi$$

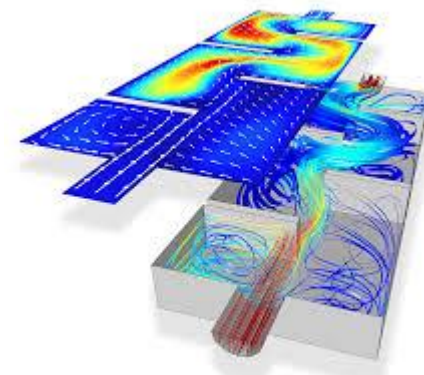

CFD应用现状

两大主要期刊发表CFD论文数量

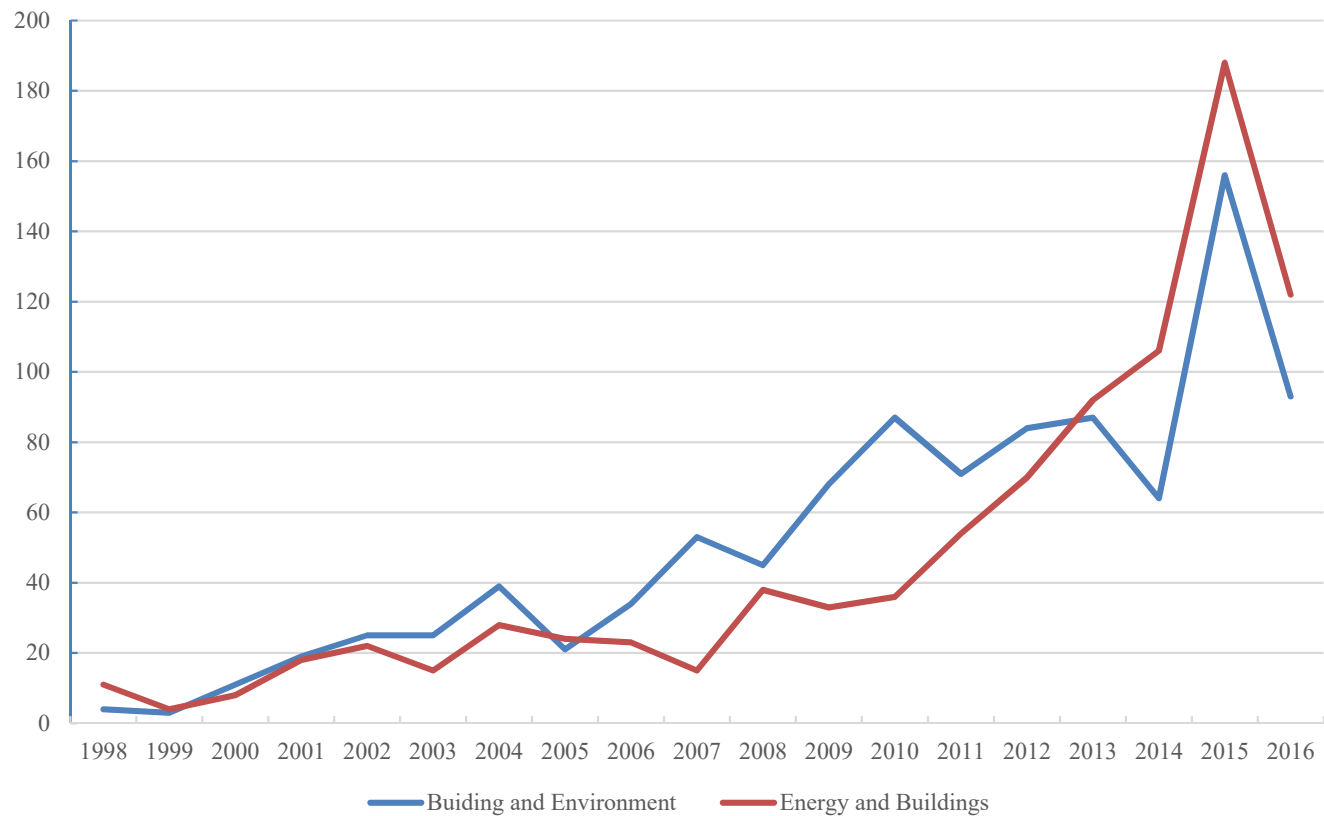

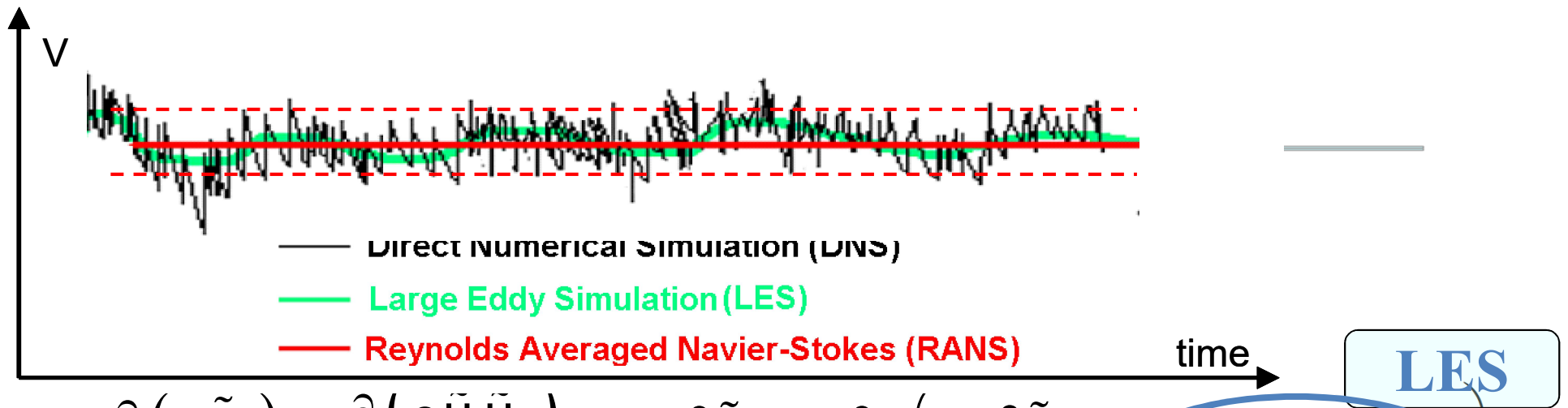

$$\frac{\partial(\rho \tilde{u}_i)}{\partial t} + \frac{\partial(\rho \tilde{u}_i \tilde{u}_j)}{\partial x_j} = -\frac{\partial \tilde{p}}{\partial x_i} + \frac{\partial}{\partial x_i} \left(\mu \frac{\partial \tilde{u}_i}{\partial x_j} - \rho (\overline{u_i u_j} - \tilde{u}_i \tilde{u}_j) \right)$$

Spatial Filtering

$$\frac{\partial(\rho u_i)}{\partial t} + \frac{\partial(\rho u_i u_j)}{\partial x_j} = -\frac{\partial p}{\partial x_i} + \frac{\partial}{\partial x_j} \left(\mu \frac{\partial u_i}{\partial x_j} \right)$$

DNS

Time Averaging

$$\frac{\partial(\rho \bar{u}_i)}{\partial t} + \frac{\partial(\rho \bar{u}_i \bar{u}_j)}{\partial x_j} = -\frac{\partial \bar{p}}{\partial x_i} + \frac{\partial}{\partial x_j} \left(\mu \frac{\partial \bar{u}_i}{\partial x_j} - \rho \overline{u_i' u_j'} \right)$$

RANS

Chen (2010)

计算方法的选择

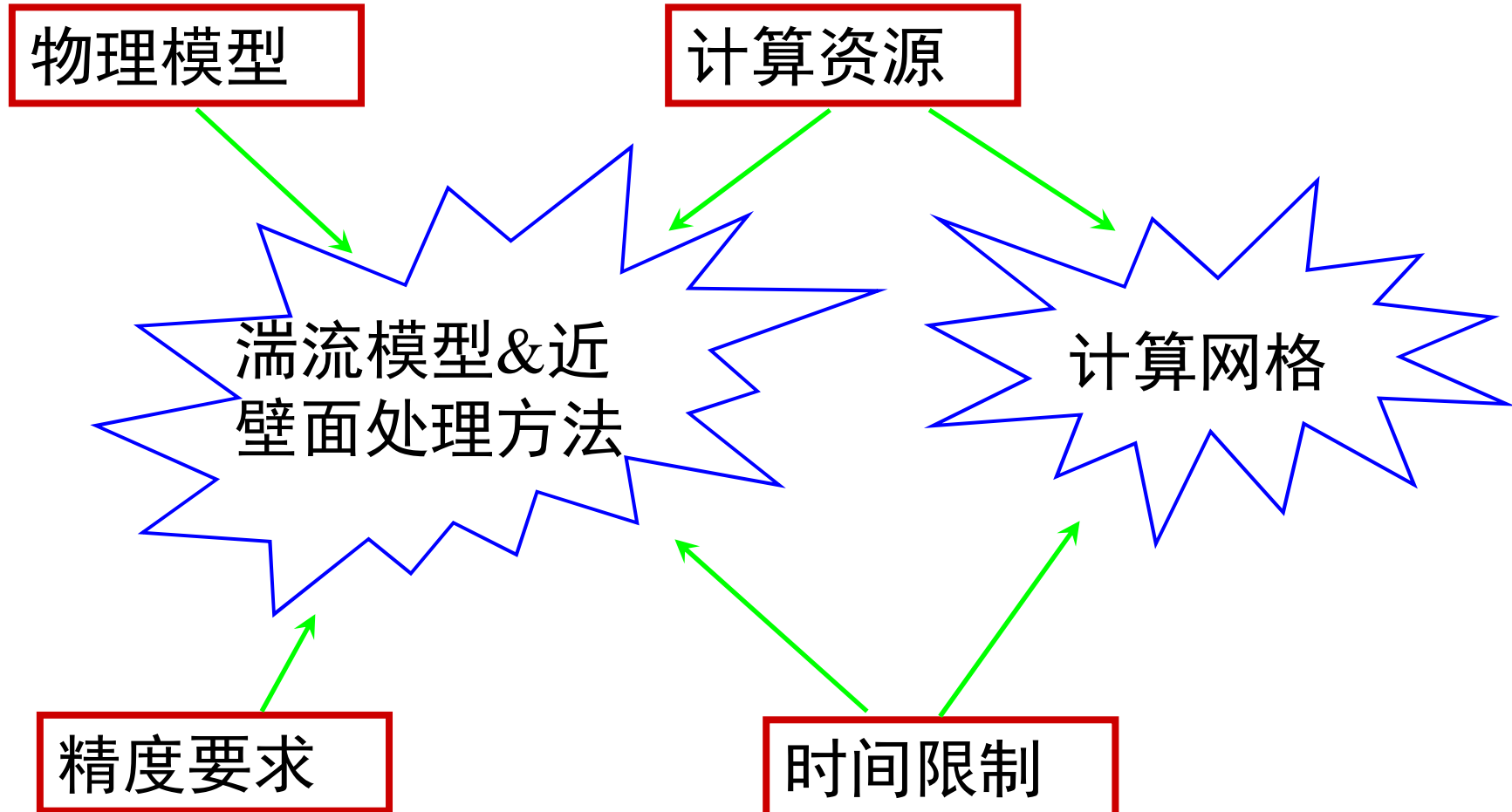

CFD模拟步骤



趋于一体化的新一代CFD软件（如Star-CCM+），易用性得到提升

无网格模拟方法

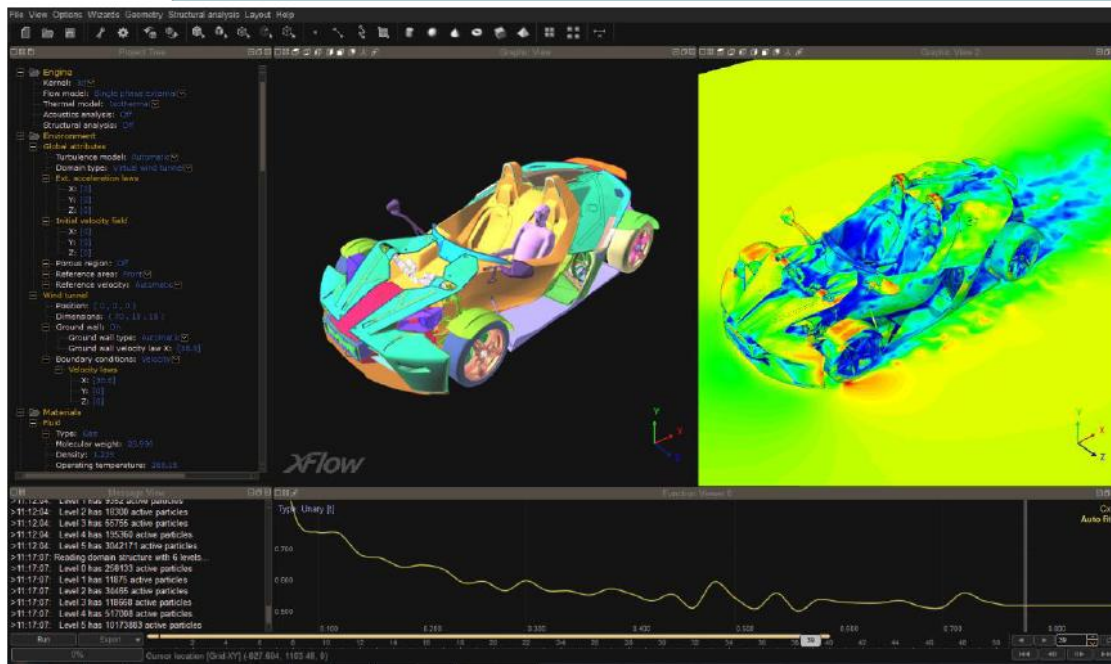

- ① 求解玻尔兹曼和可压缩N-S方程；
- ② 无网格；
- ③ 自动生成计算区域；
- ④ 对于移动问题或变计算区域问题有优势；
- ⑤ 对于输入几何模型的质量依赖小。



目录

1. 气流模拟简介
2. 人工环境领域CFD模拟的特殊问题
3. 模拟结果的质量控制
4. 案例介绍
5. 总结

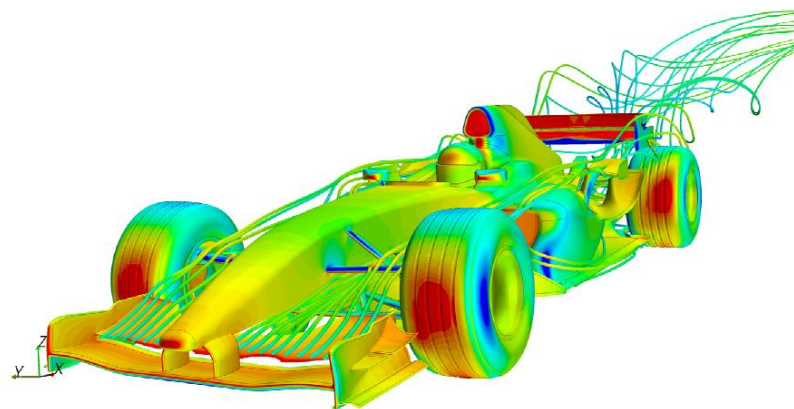

流态的多样性

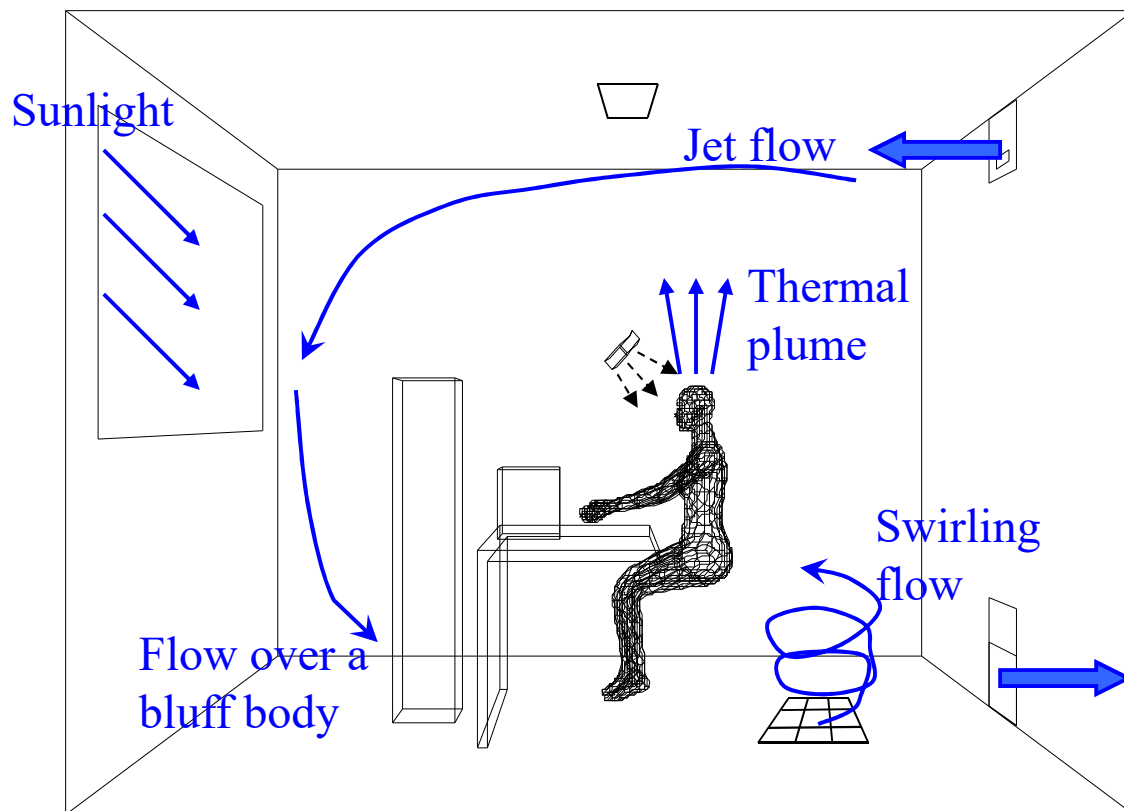

自然对流
强制对流
混合流动

辐射+对流
非等温流动
非稳态
多相流动

空间-时间尺度的多样性

空间尺度: $10^{-7}\text{m}\sim 10^3\text{m}$

- 颗粒物 $0.1\mu\text{m}\sim 100\mu\text{m}$ ($10^{-7}\sim 10^{-4}\text{m}$)
- 壁面边界层 $1\text{mm}\sim 10\text{cm}$ ($10^{-3}\sim 10^{-2}\text{m}$)
- 房间、建筑尺度 $10\text{cm}\sim 100\text{m}$ ($10^{-2}\sim 10^2\text{m}$)
- 街区尺度 1km (10^3m)

时间尺度: $10^{-1}\text{s}\sim 10^8\text{s}$

- 湍流脉动 0.1s (10^{-1}s)
- 人体的呼吸周期 10s (10^0s)
- 室内气流的时间常数 $10\text{s}\sim 1\text{h}$ ($10^1\sim 10^3\text{s}$)
- 建筑热惯性 $1\text{hour}\sim 10\text{hour}$ ($10^3\sim 10^4\text{s}$)
- 室外气象与气候条件 $1\text{day}\sim 1\text{year}$ ($10^5\sim 10^8\text{s}$)

解决办法1 ✓

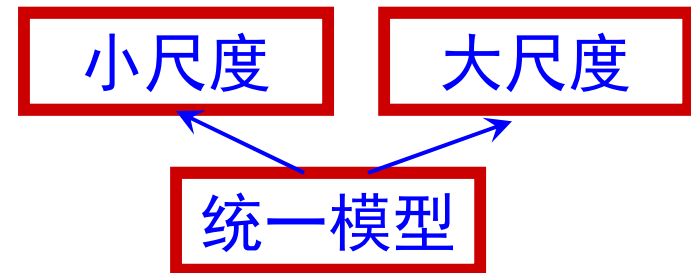

解决办法2 ✓

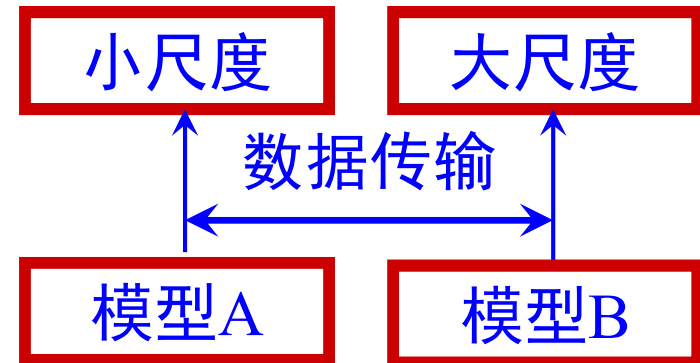

多物理场耦合

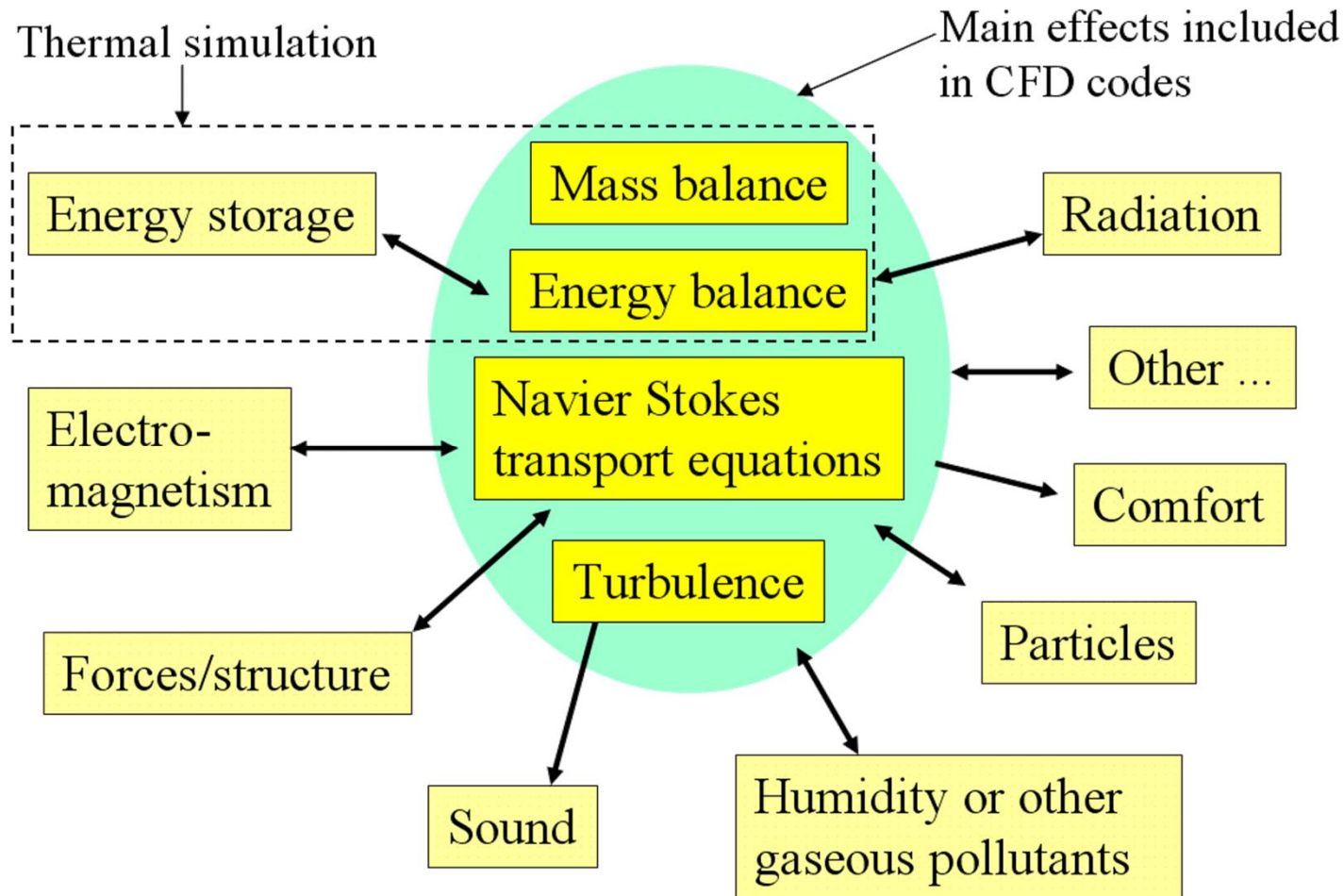

室内空气流动的相关物理模型

(Nielsen et al. 2007)

CFD+多区模拟

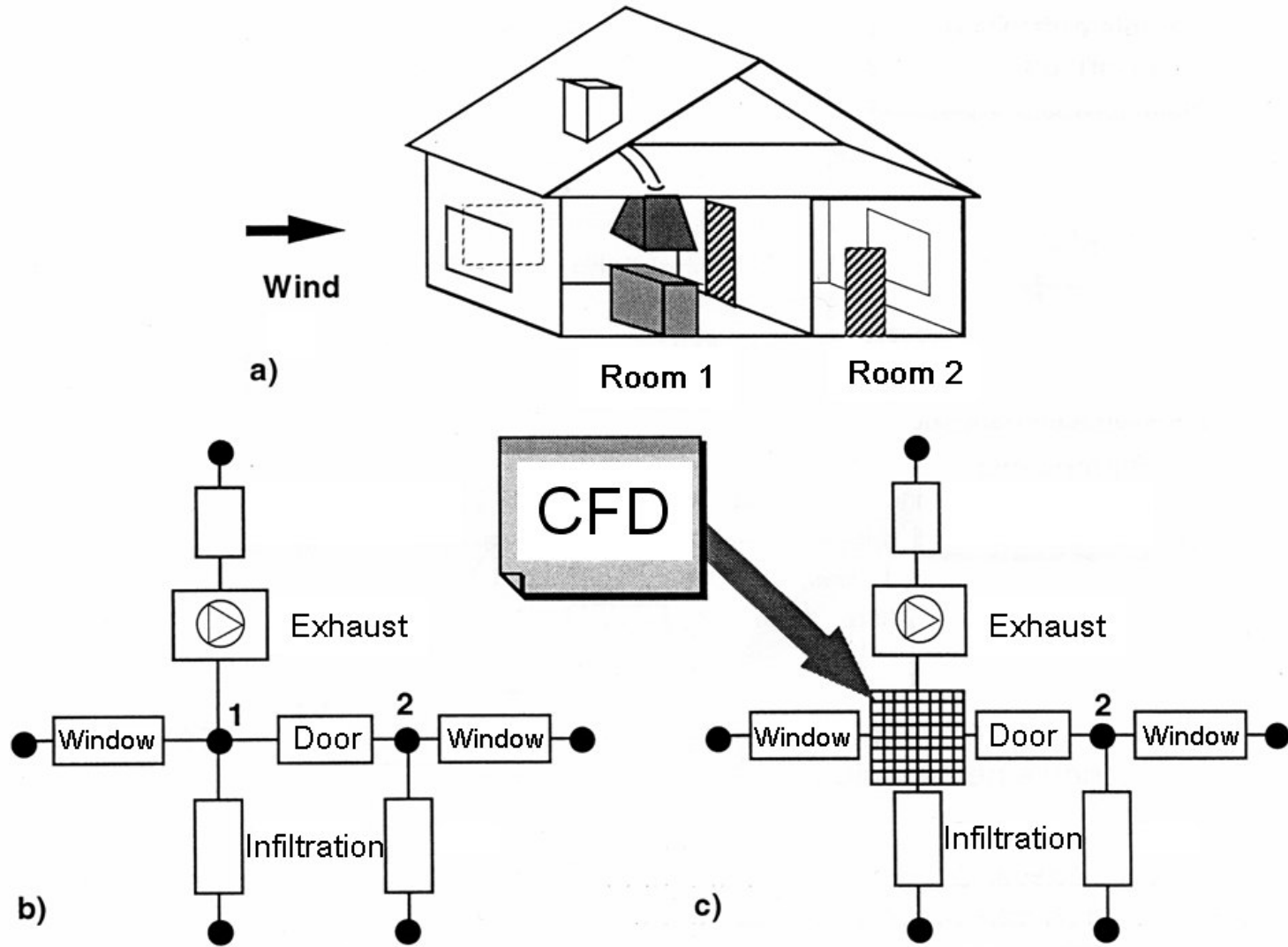

Nielsen et al. 2007

CFD+人体热调节模型

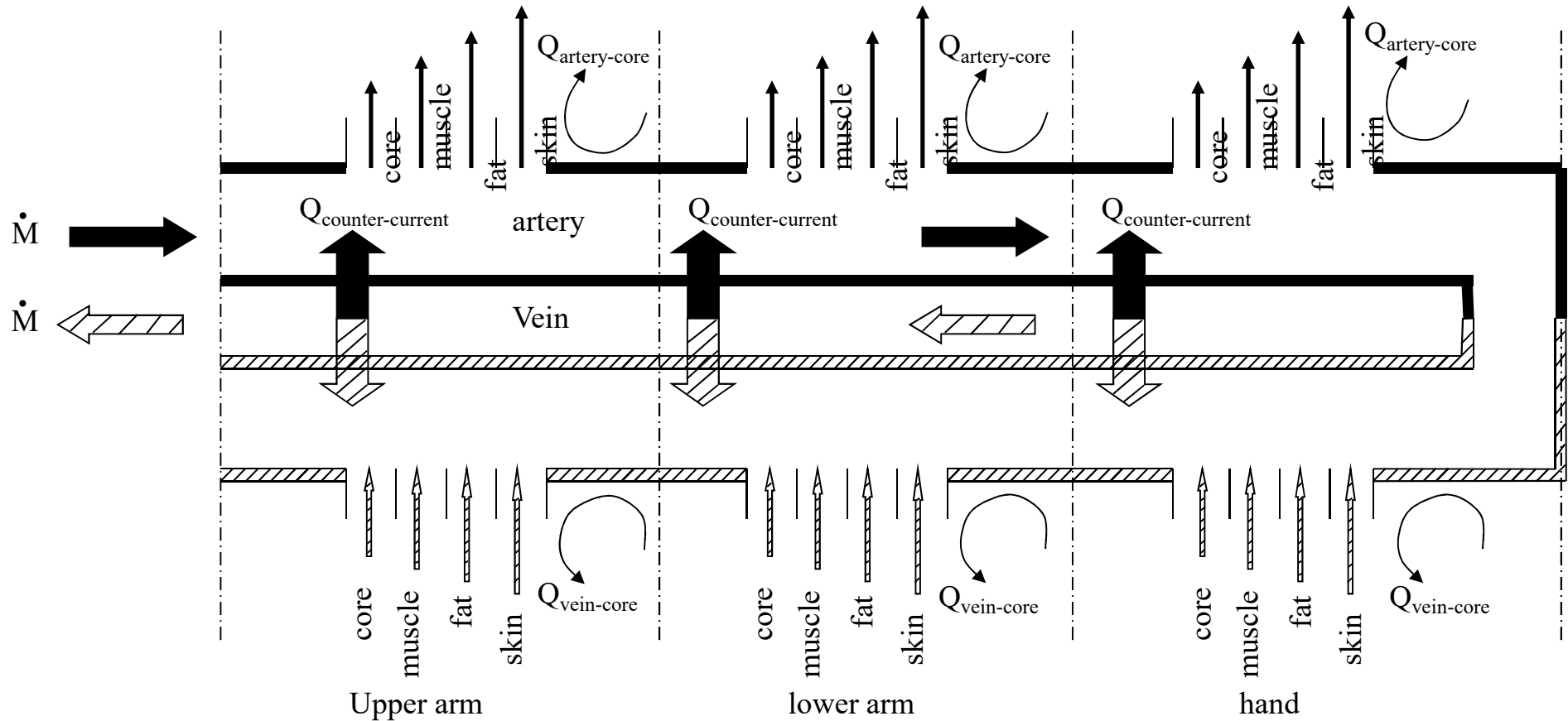

特点3

CFD+人体热调节模型

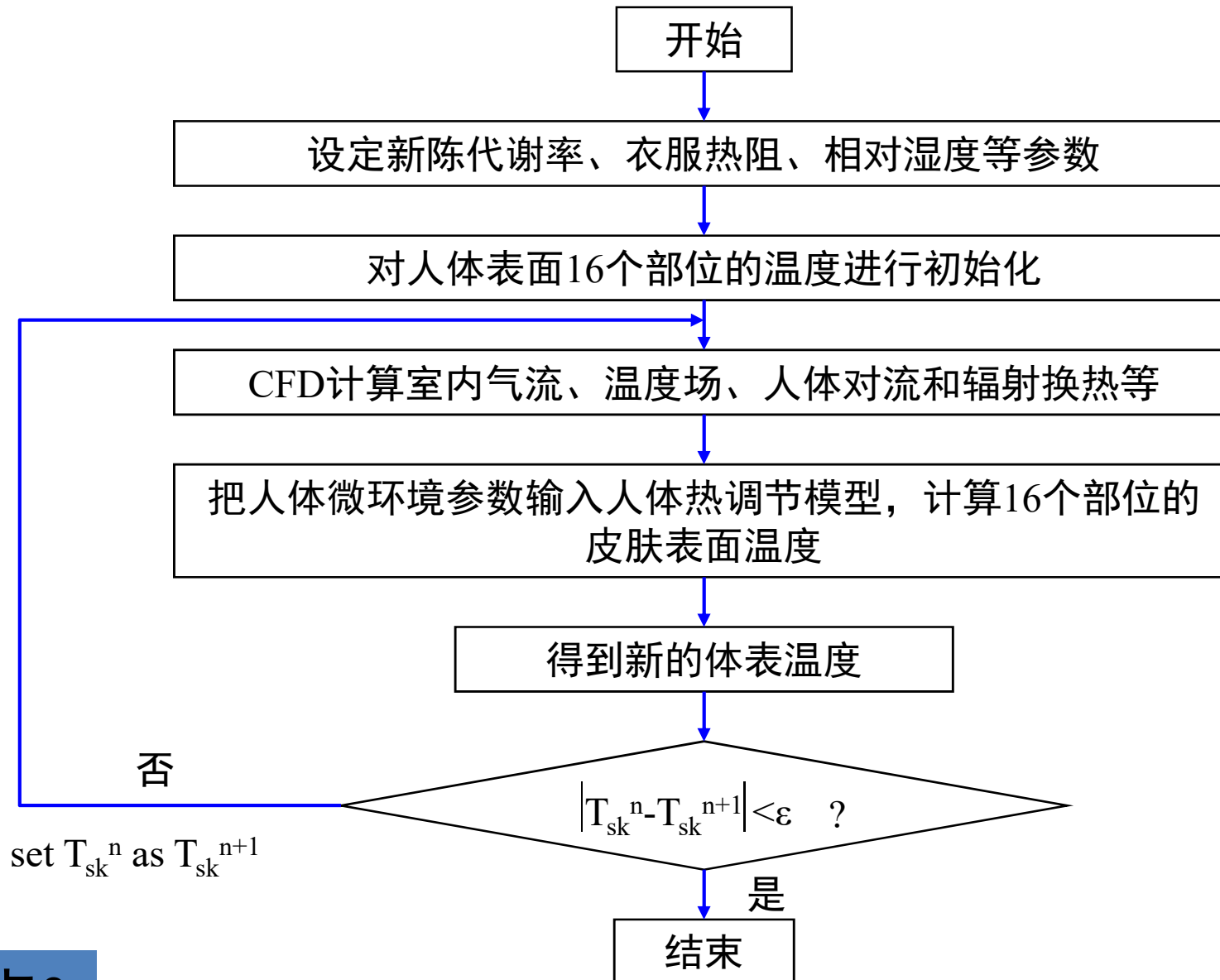

CFD+人体热调节模型

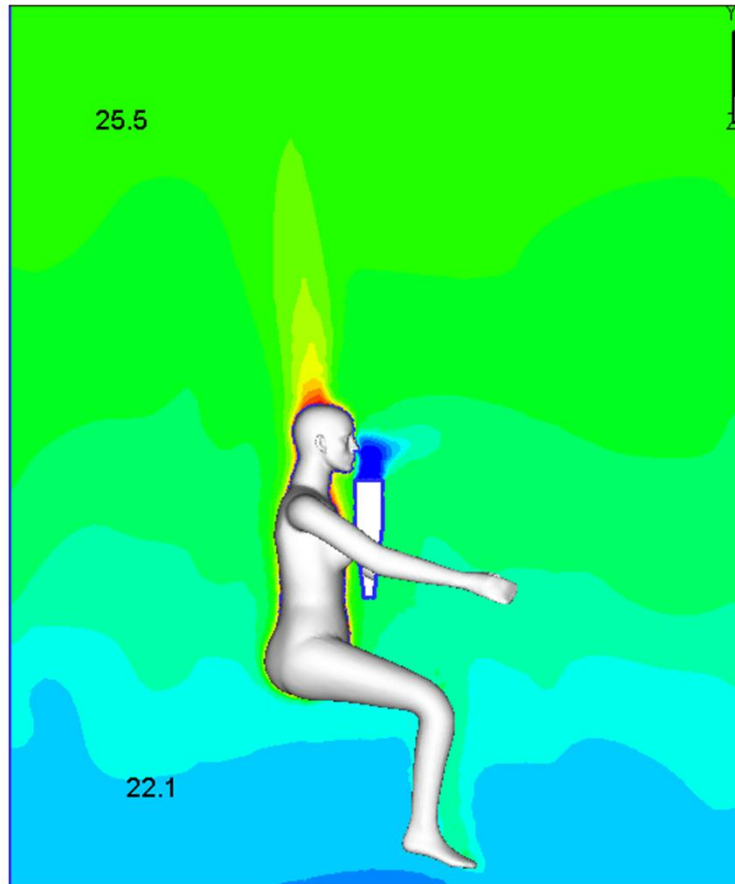

室内空气温度

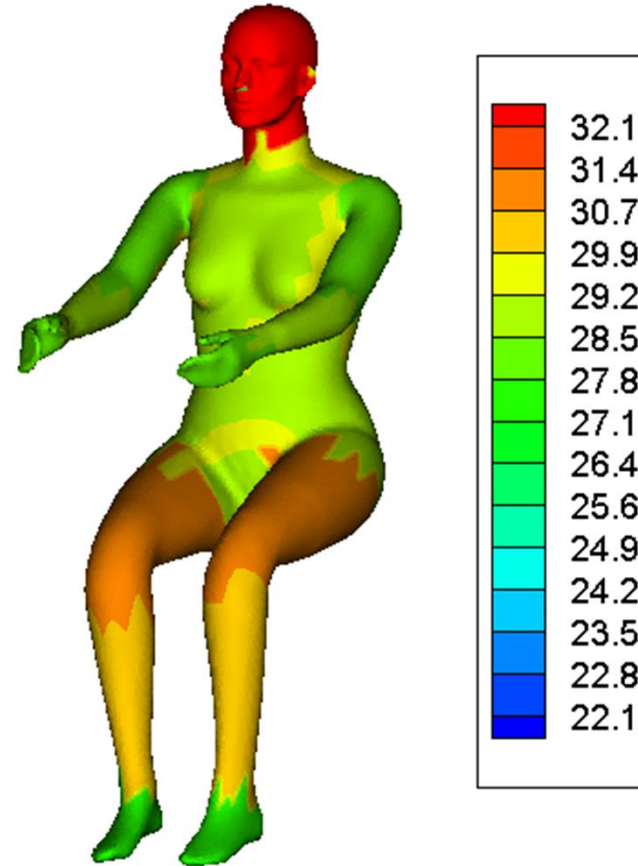

皮肤温度

虚拟热舒适工程

特点3

人工环境领域CFD模拟的特点

- 非稳态计算（冷热负荷、人体的移动、开门引起的冷量散失）
- 散流器的模拟（box method, momentum method, N-point method）
- 相变，稀疏态两相流（冷吊顶结露、PM2.5等颗粒物传输与在壁面的沉积）
- 专有的评价指标（PMV, PPD, 空气龄）
- 计算区域大、网格数量多

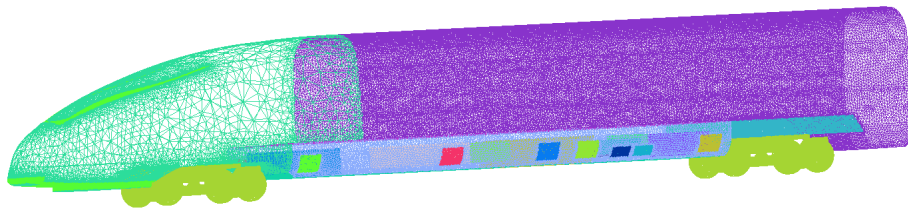
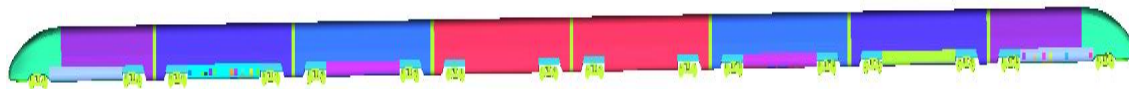

设备舱通风模拟1亿网格

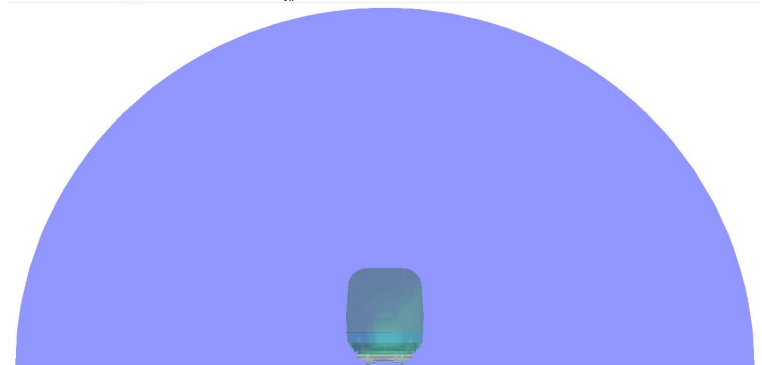
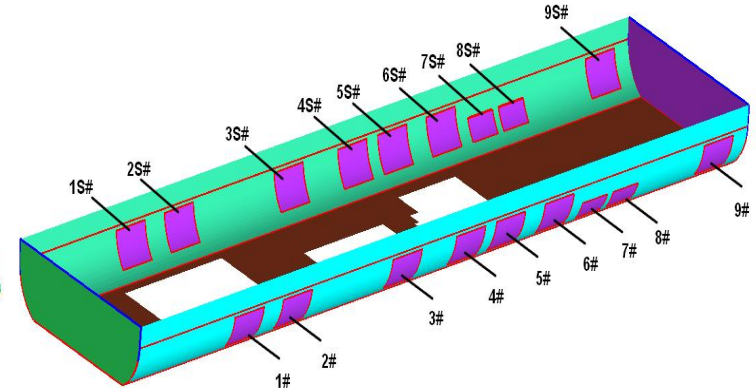
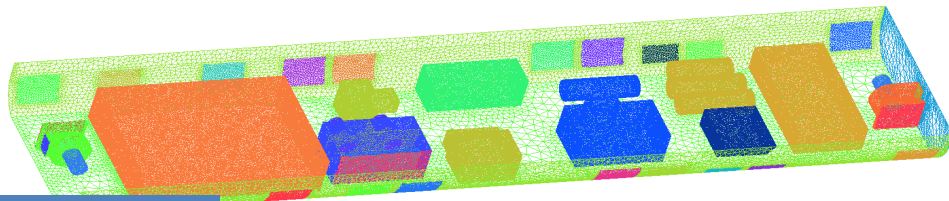

特点4

人体微气流

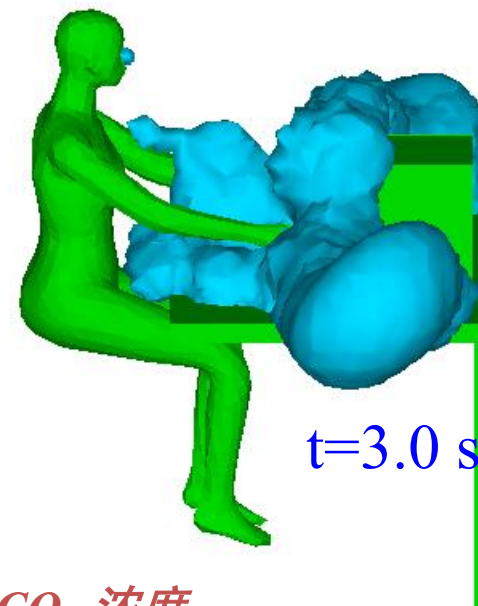
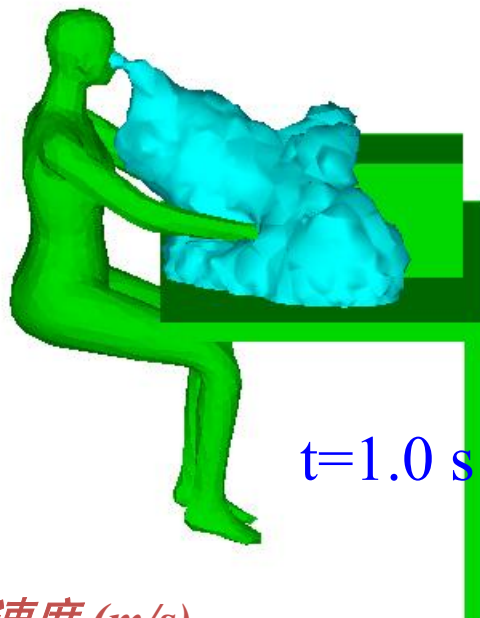
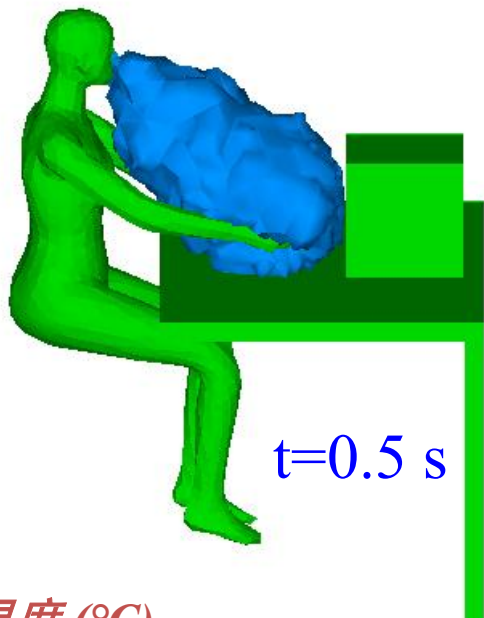

温度 ($^{\circ}\text{C}$)

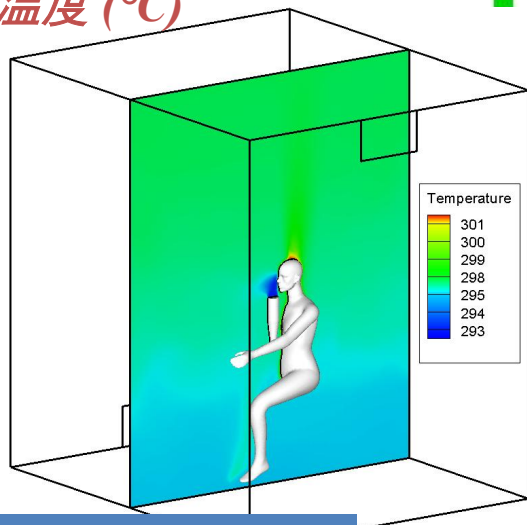

速度 (m/s)

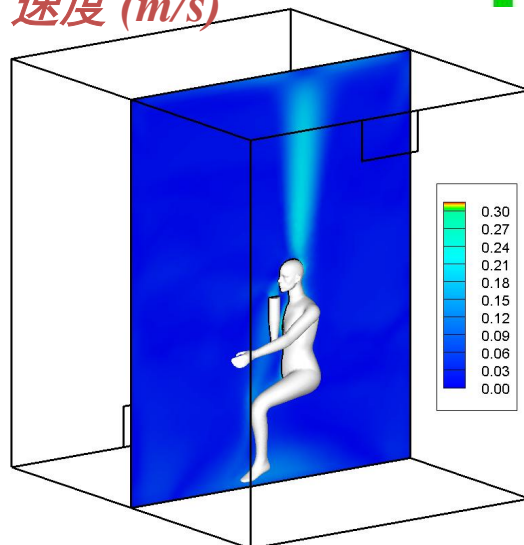

CO_2 浓度

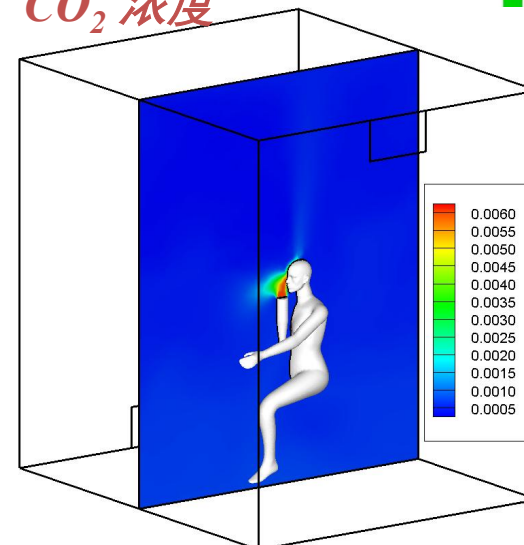

应用实例1

移动人体身后的尾涡

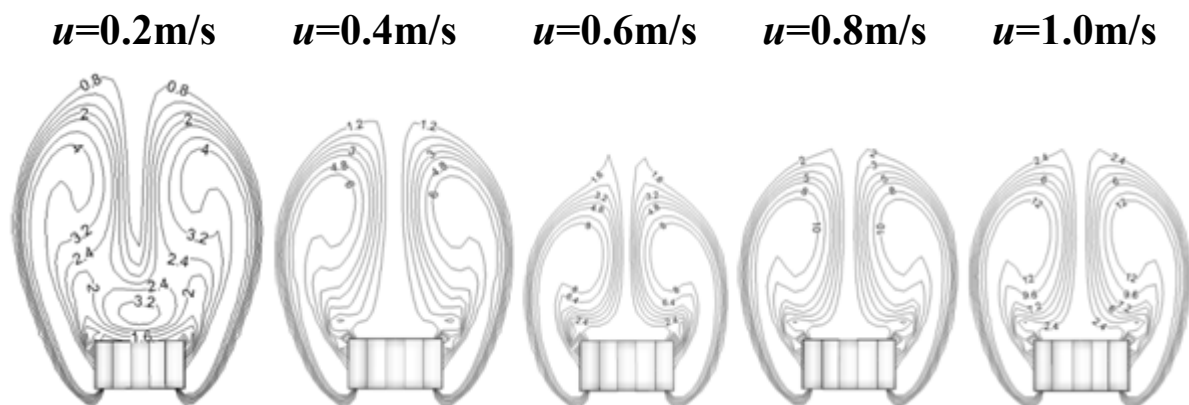

Waist section

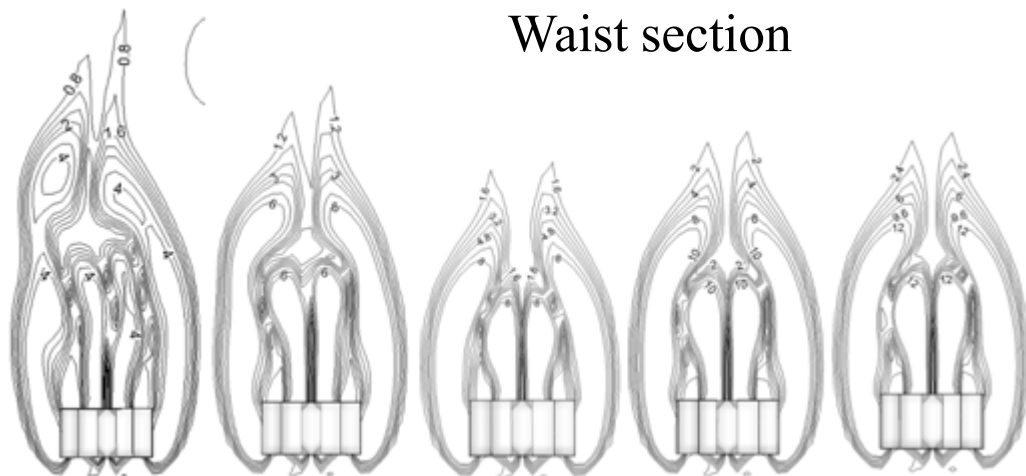

Foot section

Vortices in the wake

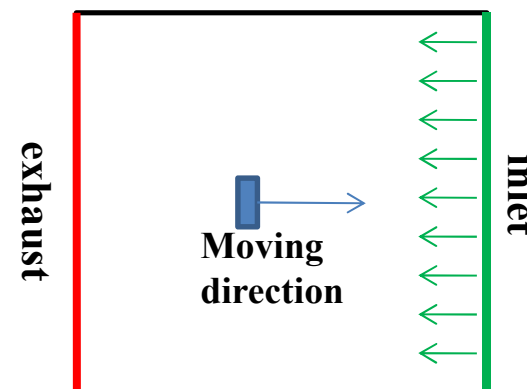

Ventilation airflow

- ① 人体后形成尾涡；
- ② 尾涡的形状随着移动速度的变化而变化；
- ③ 达到一定速度后，尾涡形状不再变化，即雷诺数独立；
- ④ 对室内流场和污染物传播产生影响。

房间之间的污染物传播

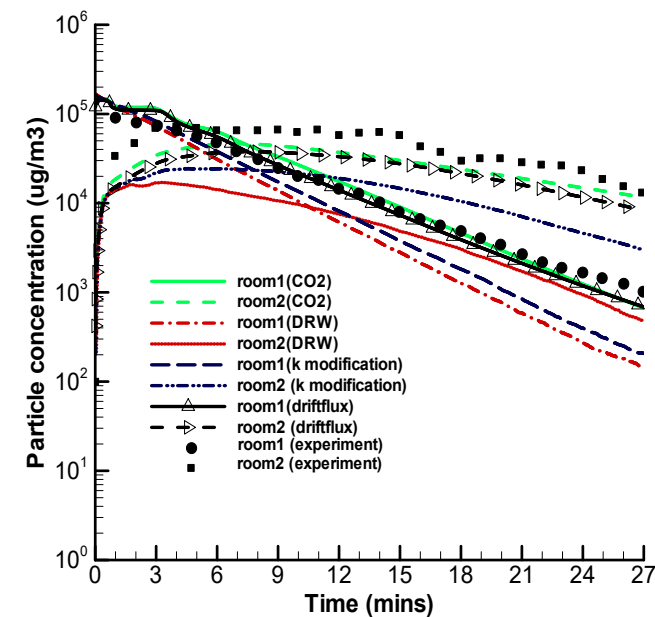
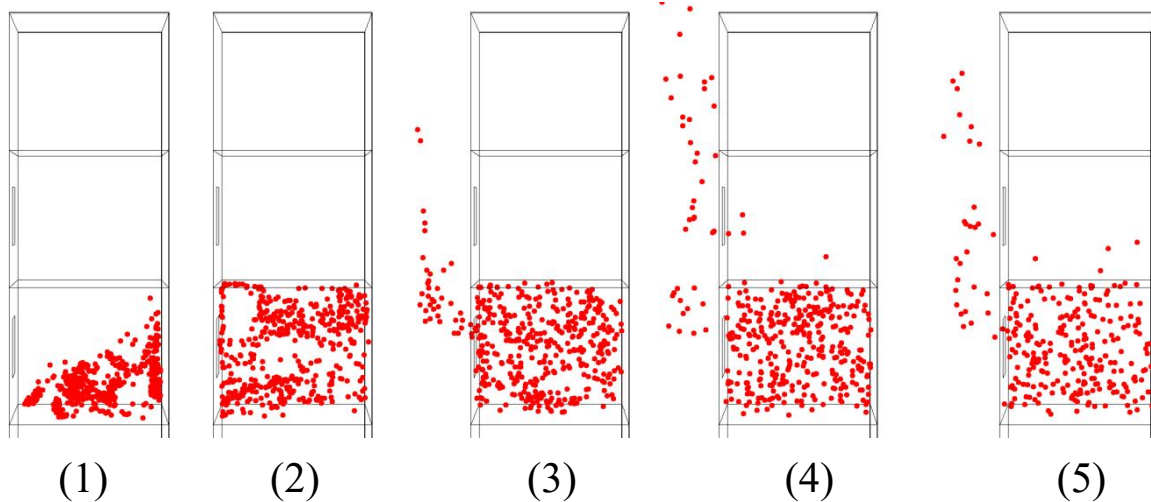
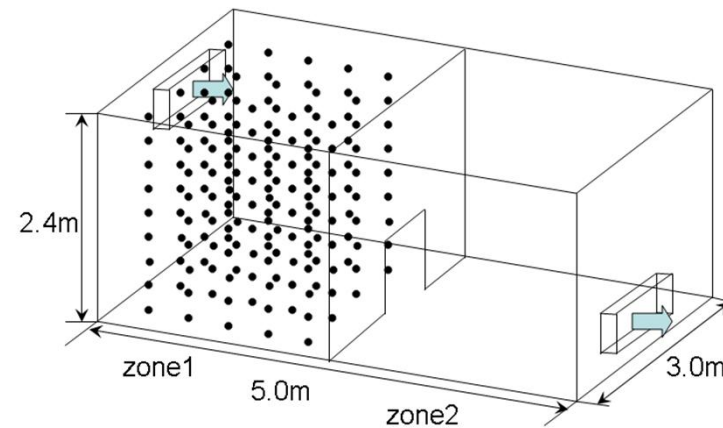
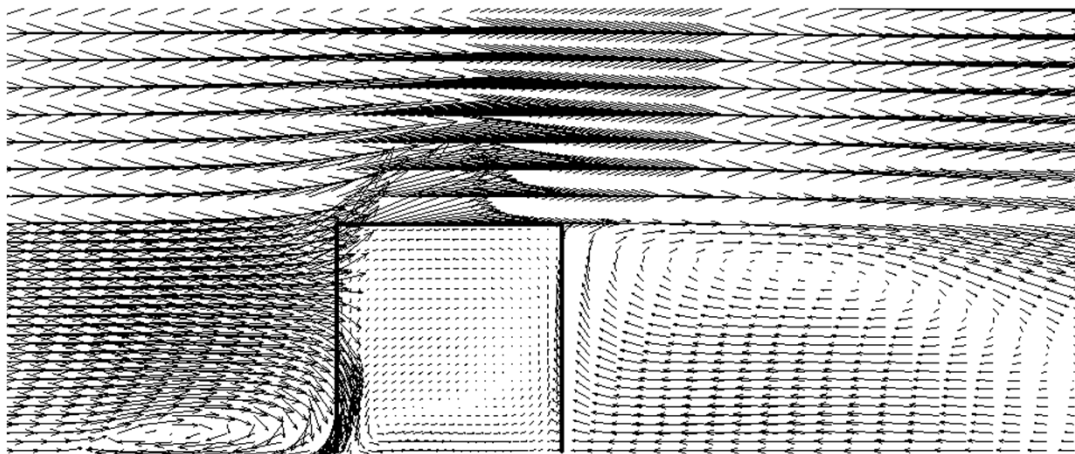

小区风环境、城市通风

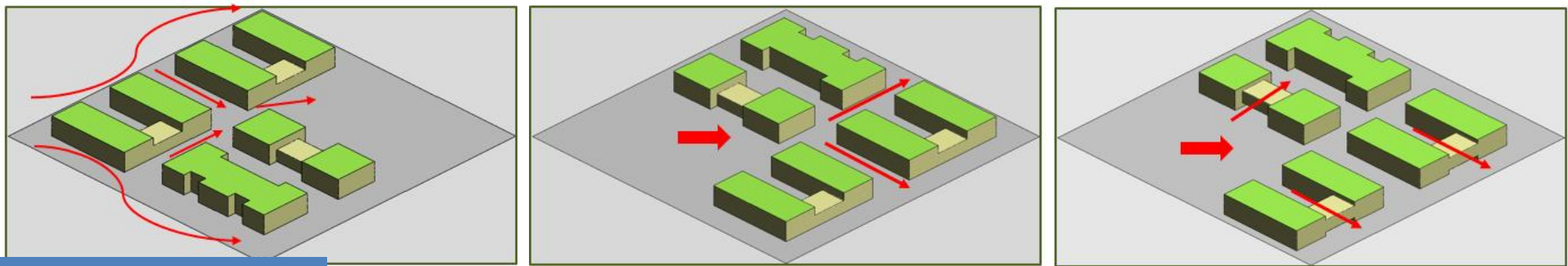
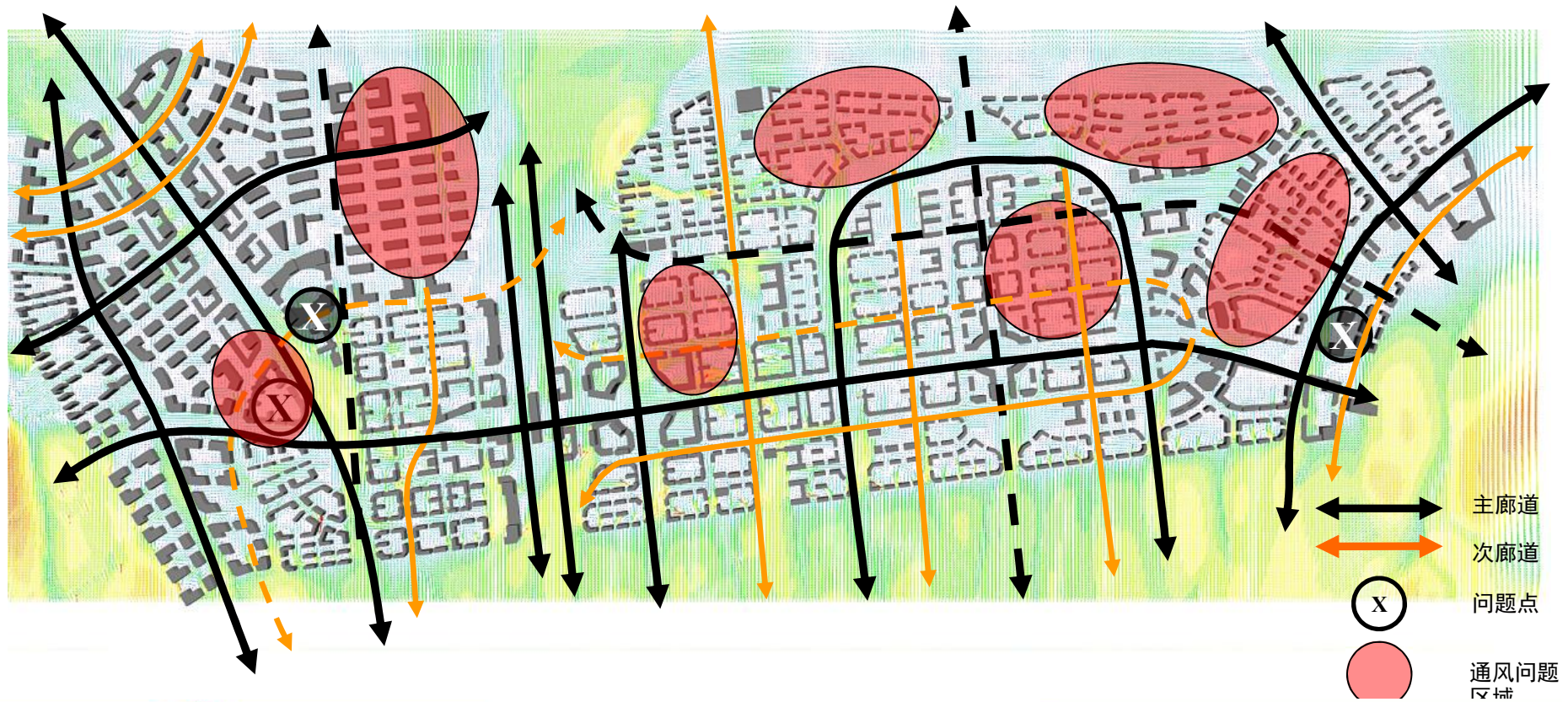

应用实例4

小结

气流仿真可以解决很多问题：

- ✓ 气流组织性能评价分析
- ✓ 自然通风的评估
- ✓ 通风效率计算
- ✓ 室内室外污染物传播与路径控制
- ✓ 围护结构的传热
- ✓

但是，CFD模拟需要注意质量控制！

目录

1. 气流模拟简介
2. 人工环境领域CFD模拟的特殊问题
- 3. 模拟结果的质量控制**
4. 案例介绍
5. 总结

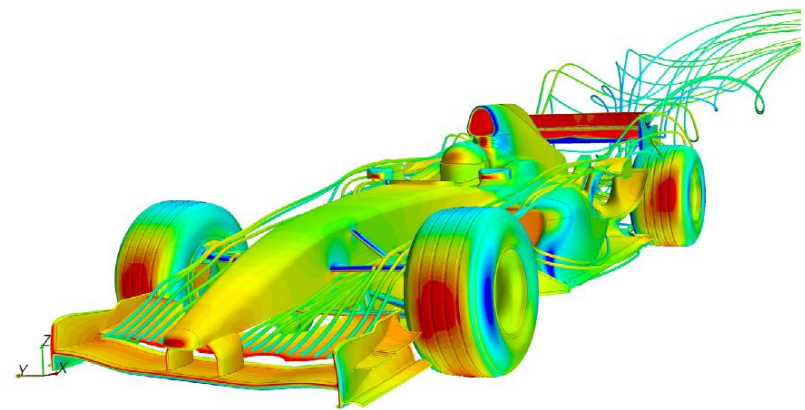

风压VS热压

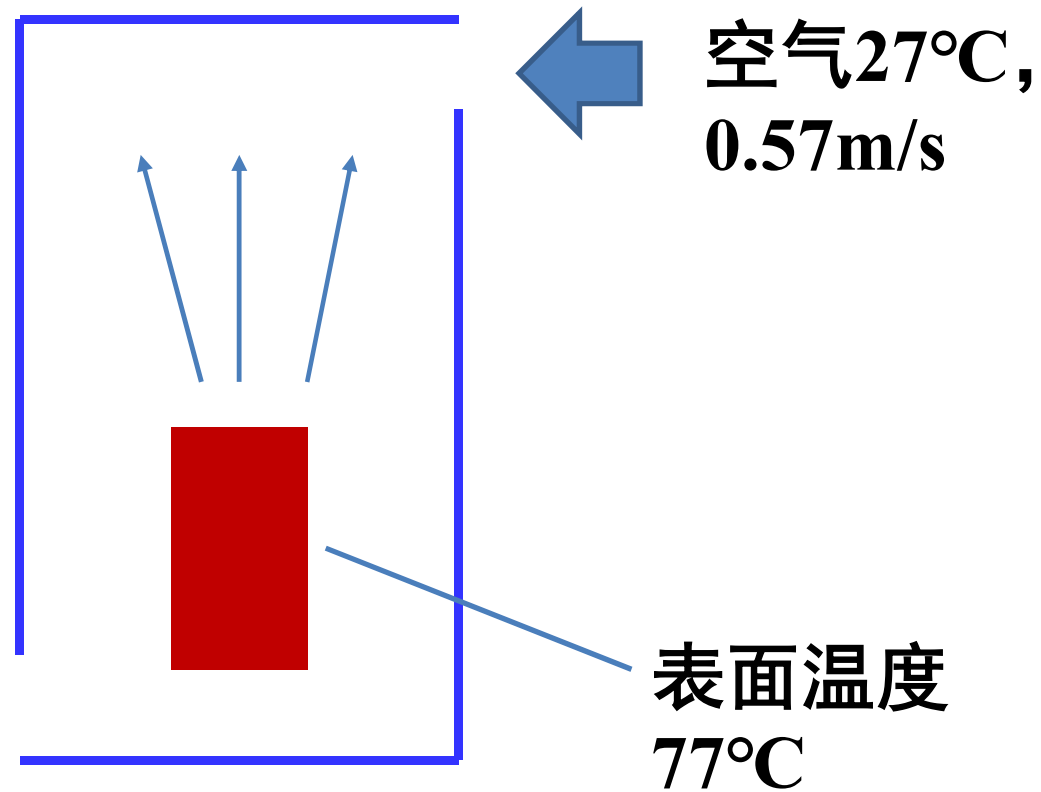

风压VS热压

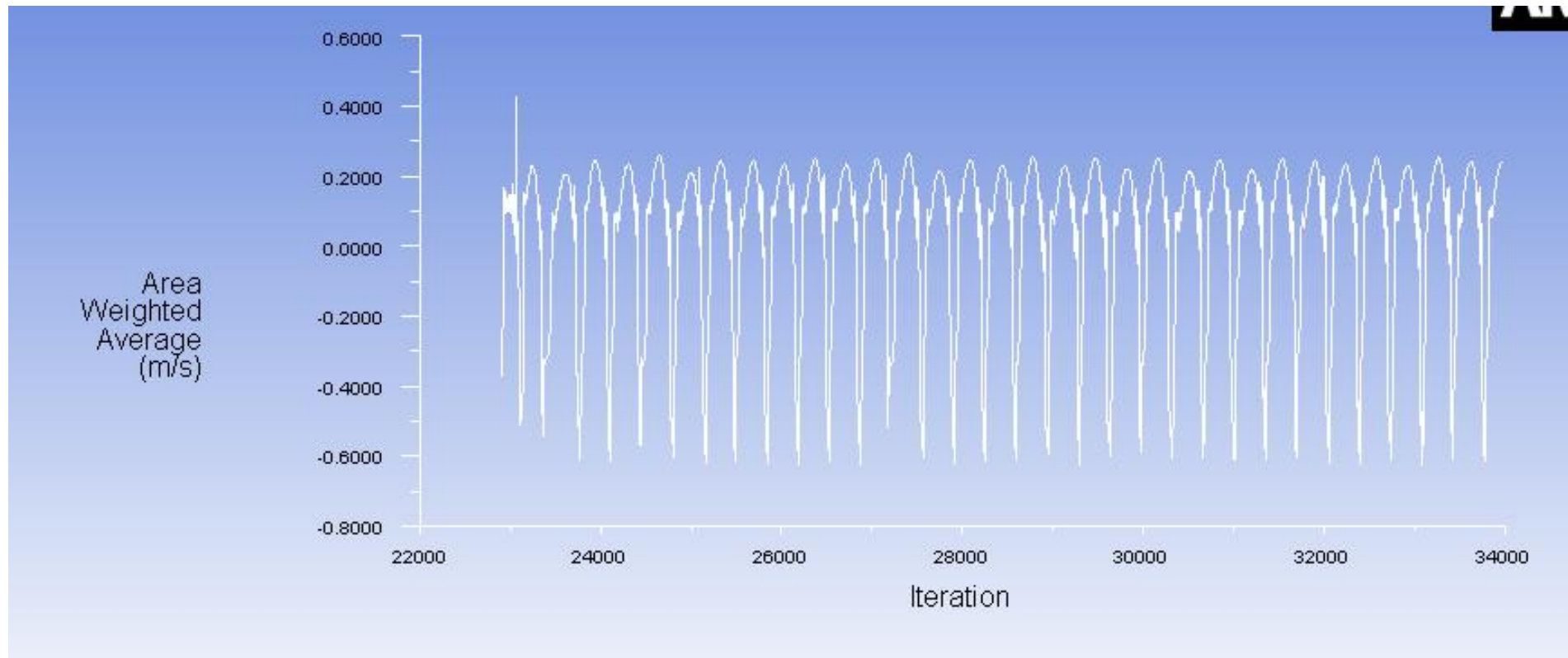

开口处的x方向速度

对称边界

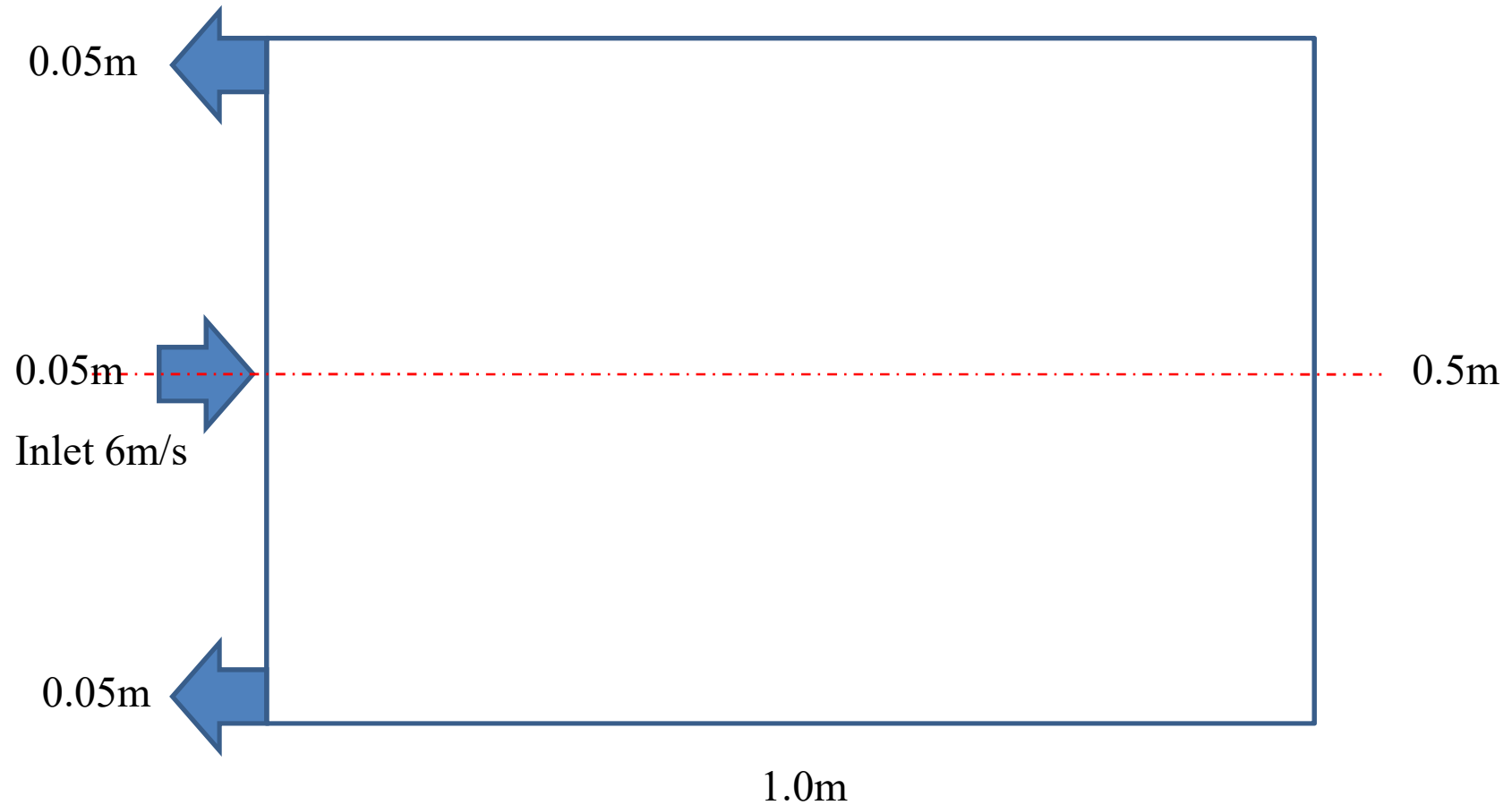

对称边界

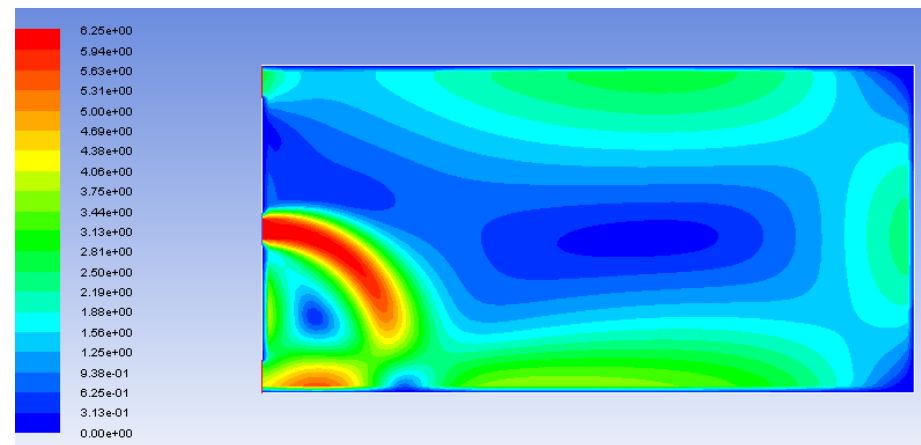
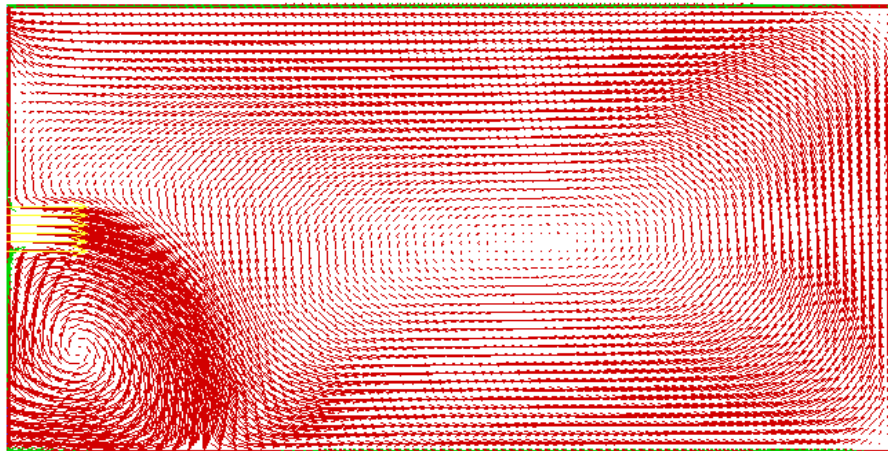
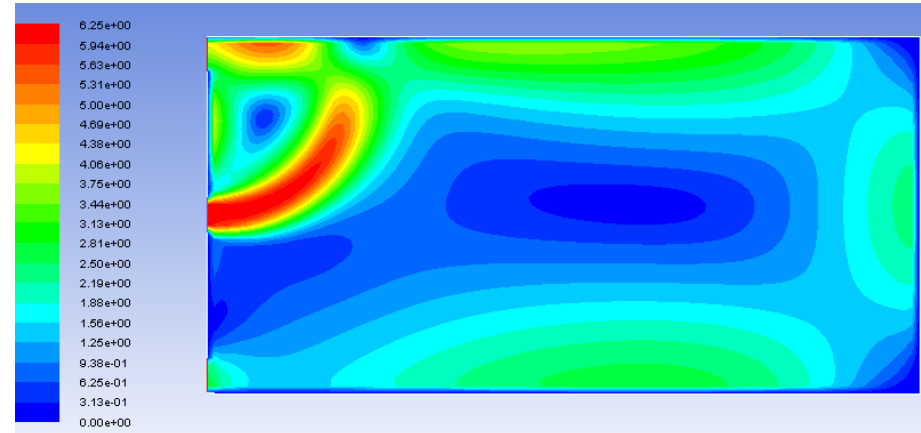
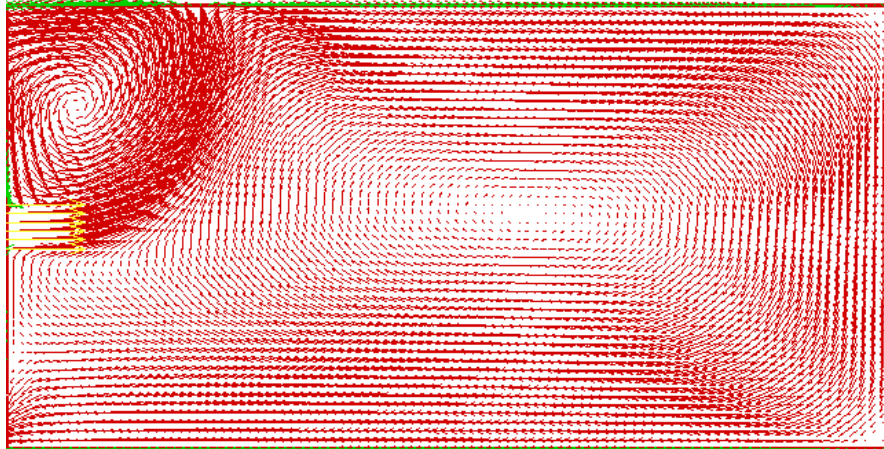

热羽流

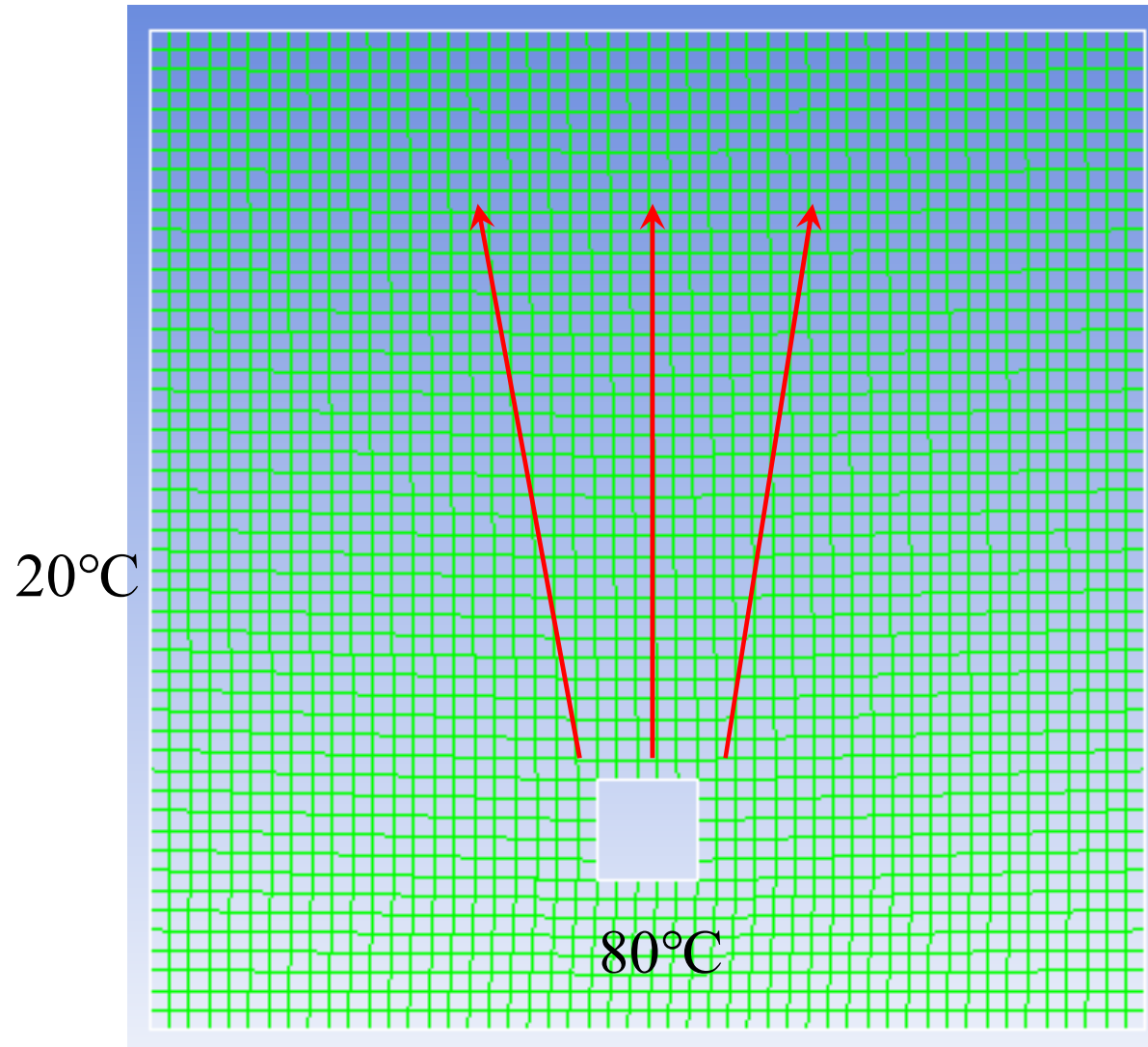

PRESTO

Second Order
Upwind

SIMPLE

热羽流

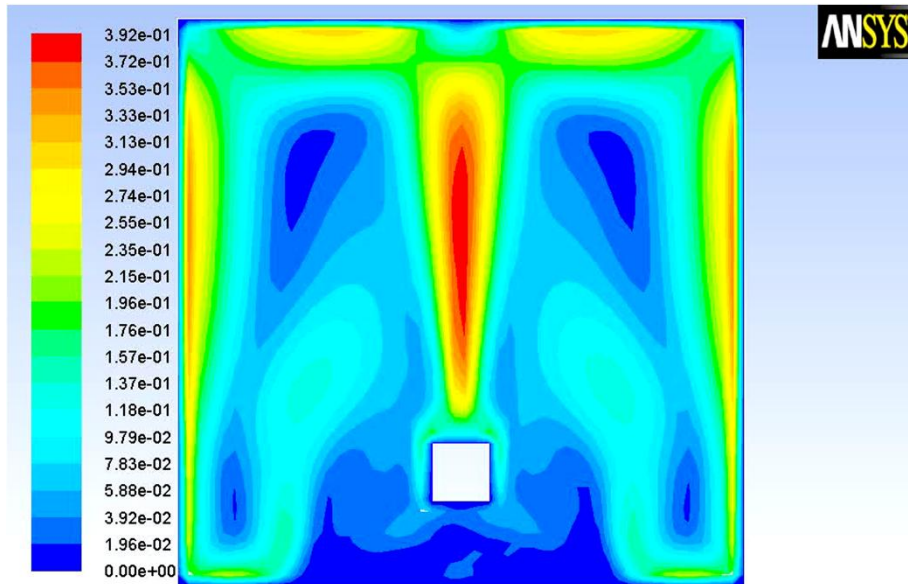

Contours of Velocity Magnitude (m/s)

May 05, 2010
ANSYS FLUENT 12.0 (2d, dp, pbns, ske)

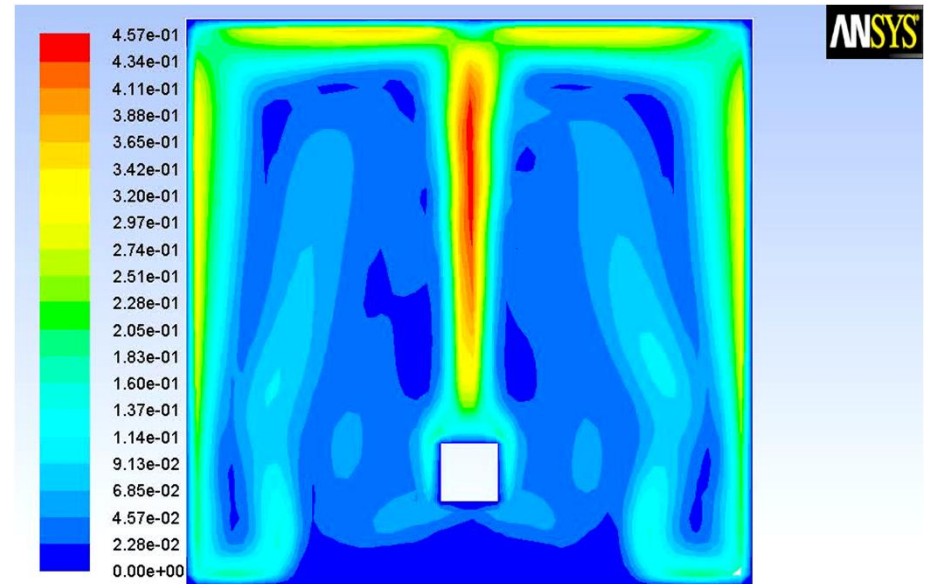

Contours of Velocity Magnitude (m/s)

Apr 28, 2010
ANSYS FLUENT 12.0 (2d, dp, pbns, rngke)

Standard k- ϵ model

RNG k- ϵ model

热羽流

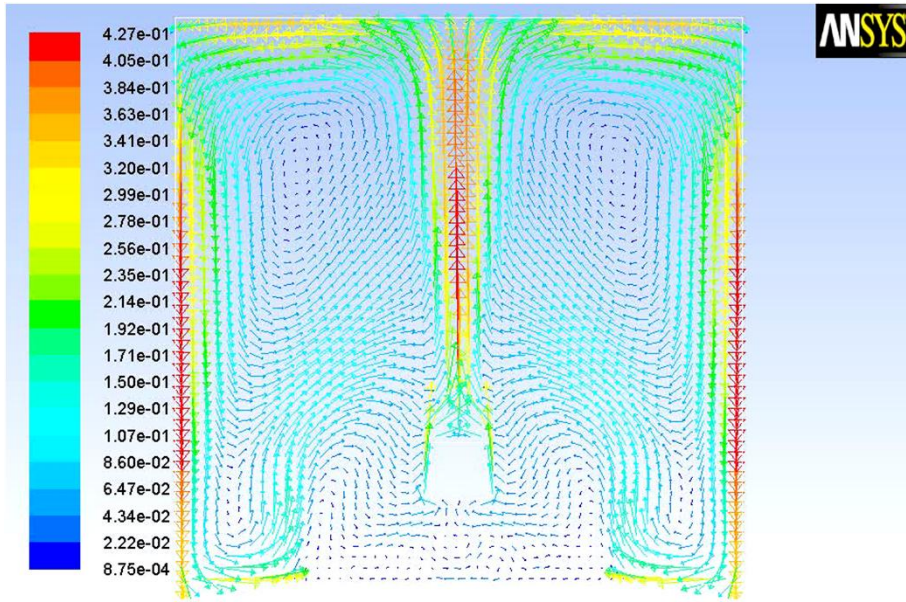

Velocity Vectors Colored By Velocity Magnitude (m/s)

May 05, 2010
ANSYS FLUENT 12.0 (2d, dp, pbns, ske)

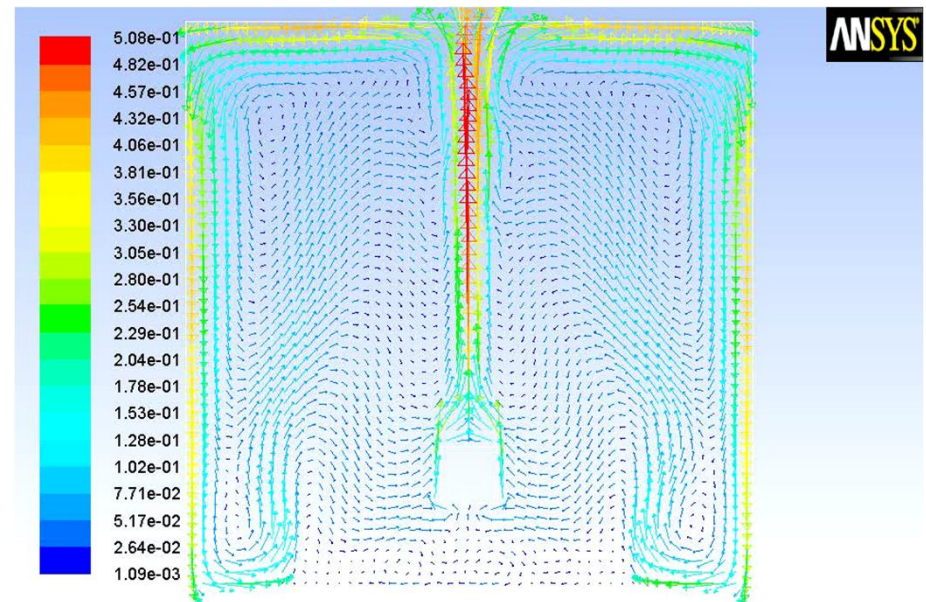

Velocity Vectors Colored By Velocity Magnitude (m/s)

Apr 28, 2010
ANSYS FLUENT 12.0 (2d, dp, pbns, rngke)

Standard k- ϵ model

RNG k- ϵ model

湍流模型与离散格式

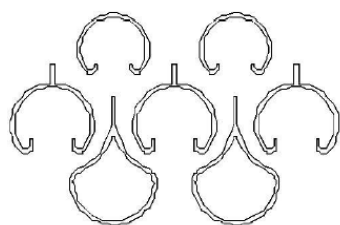
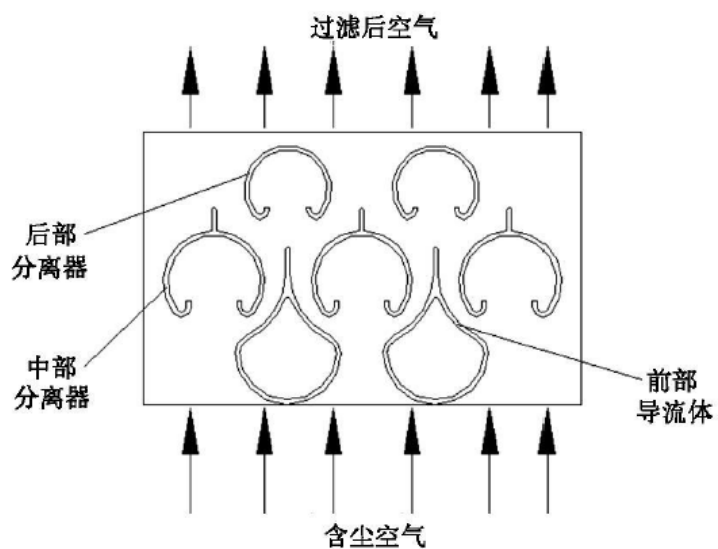

a 型过滤器

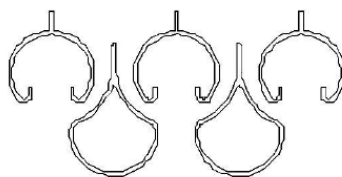

b 型过滤器

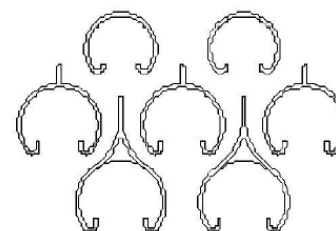

c 型过滤器

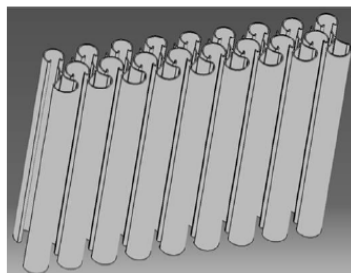

a 型过滤器

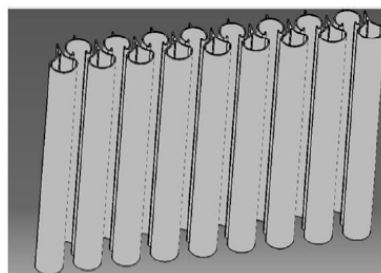

b 型过滤器

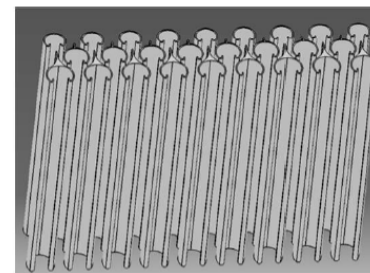

c 型过滤器

问题4

湍流模型与离散格式

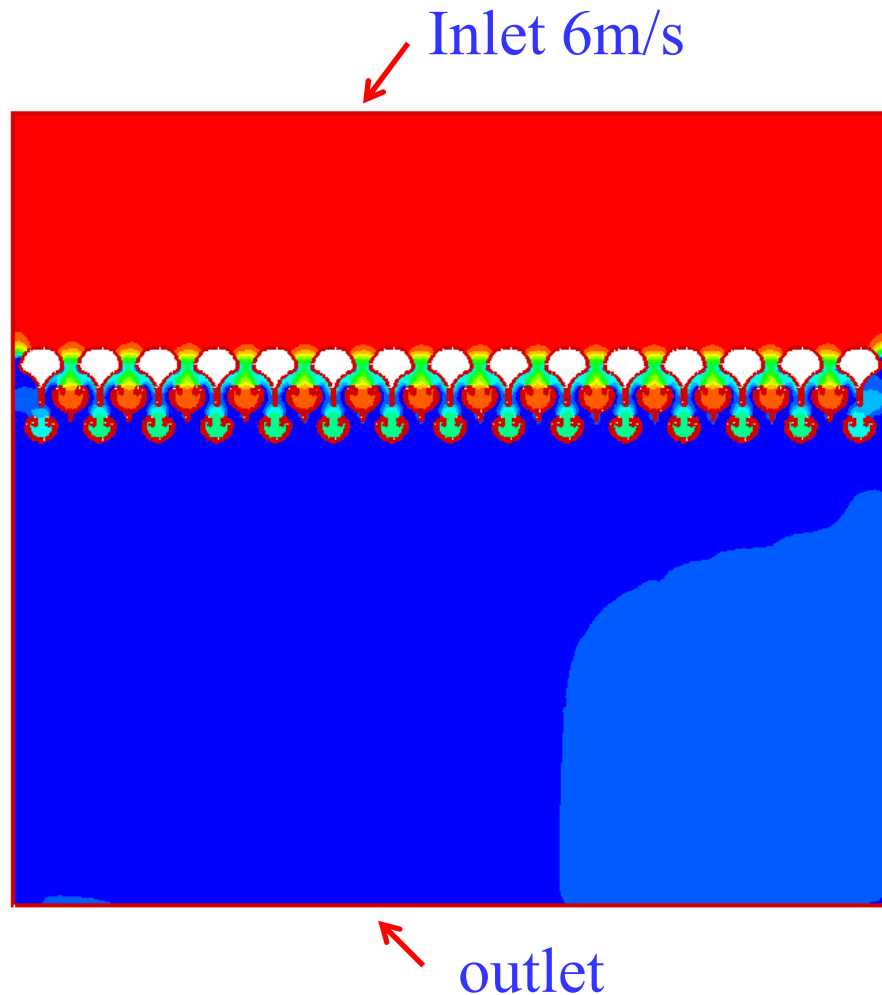

Scheme: SIMPLE

Gradient: Least Squares Cell Based

Pressure: PRESTO

Momentum: Second Order Upwind

Turbulence:

Standard k-e model

RNG k-e model

Realizable k-e model

湍流模型与离散格式

	Second Order upwind	Power Law	QUICK	Third Order MUSCL
Standard	486	557	498	517
PRESTO	327	438	317	353
Second Order	397	495	407	413
Linear	453	532	458	471
Body Force Weighted	464	523	449	486

**Standard
k-ε model**

	Second Order upwind	Power Law	QUICK	Third Order MUSCL
Standard	349	390	304	369
PRESTO	130	265	115	121
Second Order	235	327	210	240
Linear	328	376	290	344
Body Force Weighted	344	385	301	358

**RNG
k-ε model**

	Second Order upwind	Power Law	QUICK	Third Order MUSCL
Standard	336	394	316	346
PRESTO	168	286	158	172
Second Order	253	341	240	260
Linear	319	386	301	326
Body Force Weighted	329	389	309	331

**Realizable
k-ε model**

使用者带来的不确定性

Introduction

- ISHVAC - COBEE 2015 Workshop (Isothermal)
- Indoor Air 2016 Workshop (Non-isothermal)
 - Flow problem

- Backward facing step with heated wall below supply

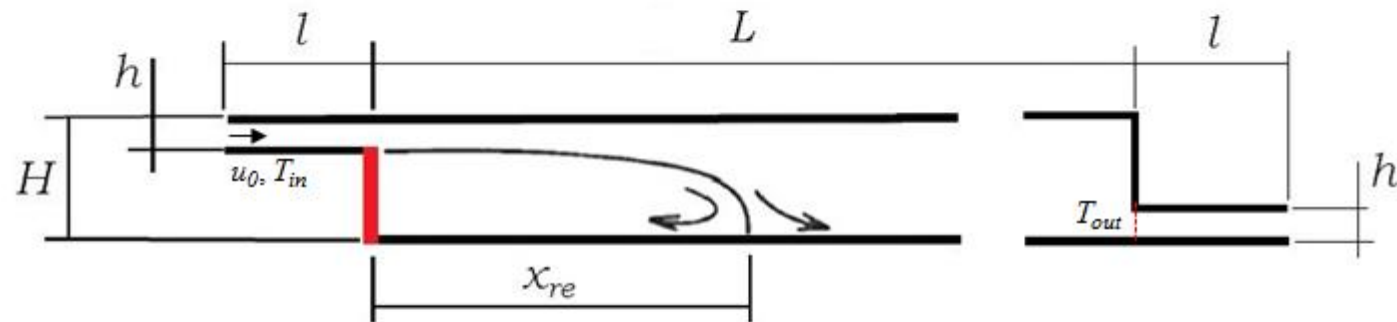

- Dimensions:

- $h/H = 1/5$
- $l/h = 4$
- $L = 10H$

$$Re = (h \cdot u_0) / \nu$$

$$Re = 10,000$$

$$Ar = \frac{\beta g H \Delta T_o}{u_0^2}$$

$$Ar = 0 \sim 8$$

使用者带来的不确定性

Names	Affiliations	Country
Alessandro Ceci, Leonardo Gastelum	KTH Stockholm	Sweden
Anders Berg, Mohammad Reza Adili	Universität Stuttgart	Germany
Bin Zhou, Kai Lin, Jiang-Bei Hu, Yue Zhang, Le-Tian Xia	Nanjing Tech University	China
Bin Zhou, Wei-Kang Zhang, Ke Xue, Rui Zhang, Dan-Dan Zhang, Xiao-Yu Zhang	Nanjing Tech University	China
Chao-Hsin Lin, Ray Horstman	Boeing Company	USA
Dimitris Fidaros, Catherine Baxevanou, Thomas Bartzanas	IRETETH-CERTH	Greece
Gao Naiping, Mu Di	Tongji University	China
Haidong Wang, Sai Lu, Feng Gao	University of Shanghai for Science and Technology	China
Hideaki Nagano, Shinsuke Kato		
Hua Qian		
Ito Kazuhide		
Jianshun Zhang, Meng Kong		
Jo-Hendrik Thysen		
Katarina Kosutova		
Li Liu		
Li Rong		
Li Wang, Shinsuke Kato		
Lucie Dobiášová		
Mathias Cehlin, Arman Ameen, Taghi Karimipannah		
Paul Mathis, Mark Wesseling		
Pekka Kanerva, Panu Mustakallio		
Risto Kosonen, Sami Lestinen		
Ruijun Zhang, Parham A. Mirzaei		
Sandro Tavares Conceição, Ramon Papa		
Sasan Sadrizadeh		
Shijie Cao, Yu Zhou	Soochow University	China
Stephen Wan, Daniel Wise, Venugopalan Srinivasa Gopala Raghavan, Poh Hee Joo	Institute of High Performance Computing	Singapore
Tengfei(Tim) Zhang, Jihong Wang, Shugang Wang	Dalian University of Technology	China
Tunc Askan	TU Berlin	Germany
Wangda Zuo, Wei Tian	University of Miami	USA
Xianting Li, Huan Wang	Tsinghua University	China
Yi Wang, Yu Zhou	Xi'an University of Architecture & Technology	China

○ 32 teams submitting 55 sets of simulations

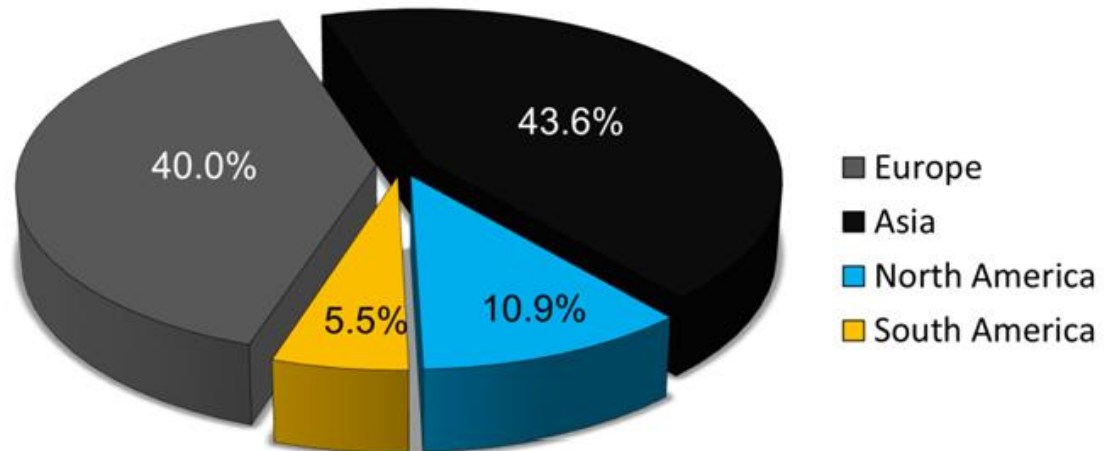

使用者带来的不确定性

求解软件：

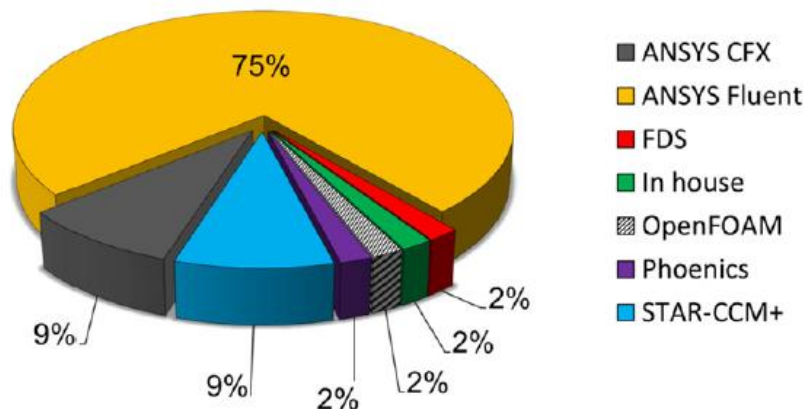

湍流模型：

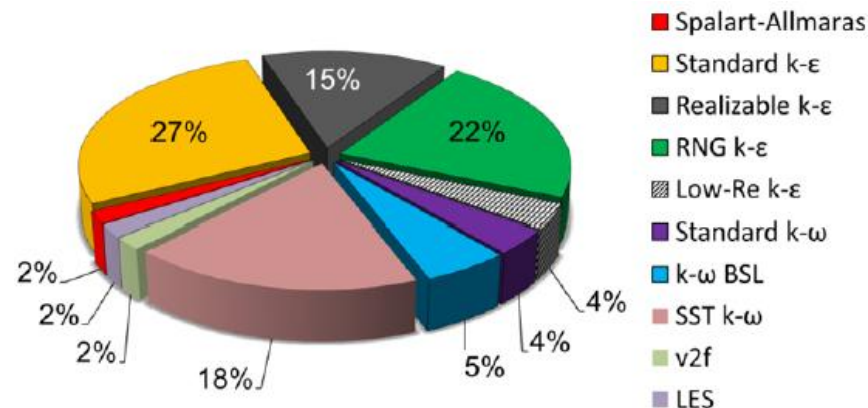

离散格式：

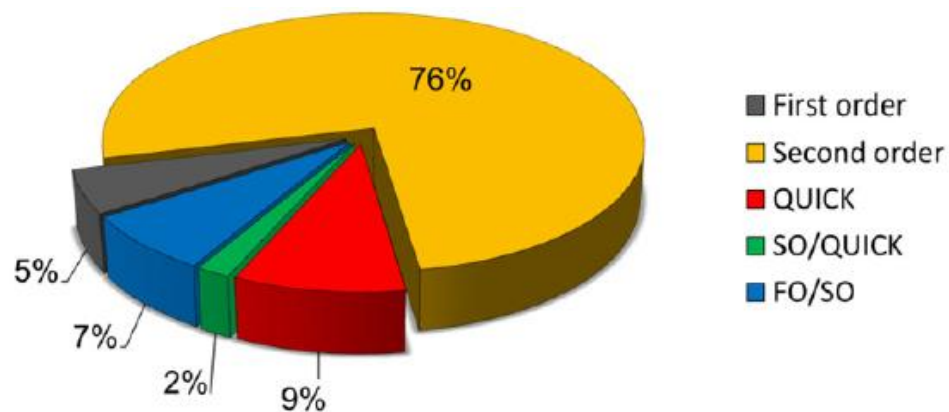

压力速度耦合算法：

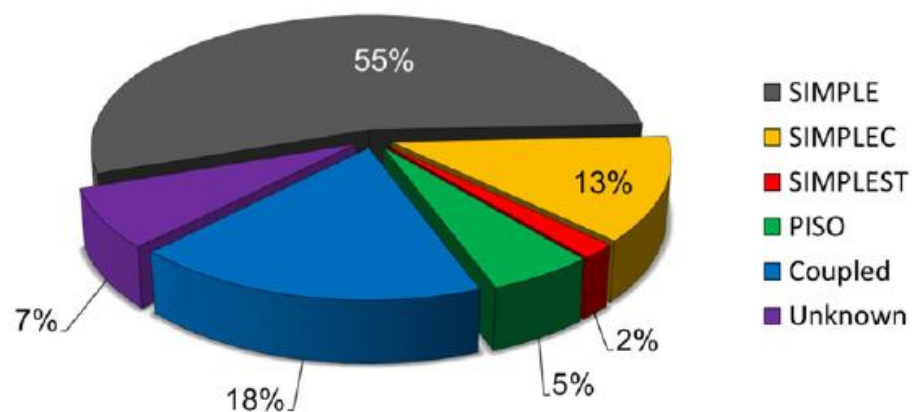

使用者带来的不确定性

不同的网格划分策略

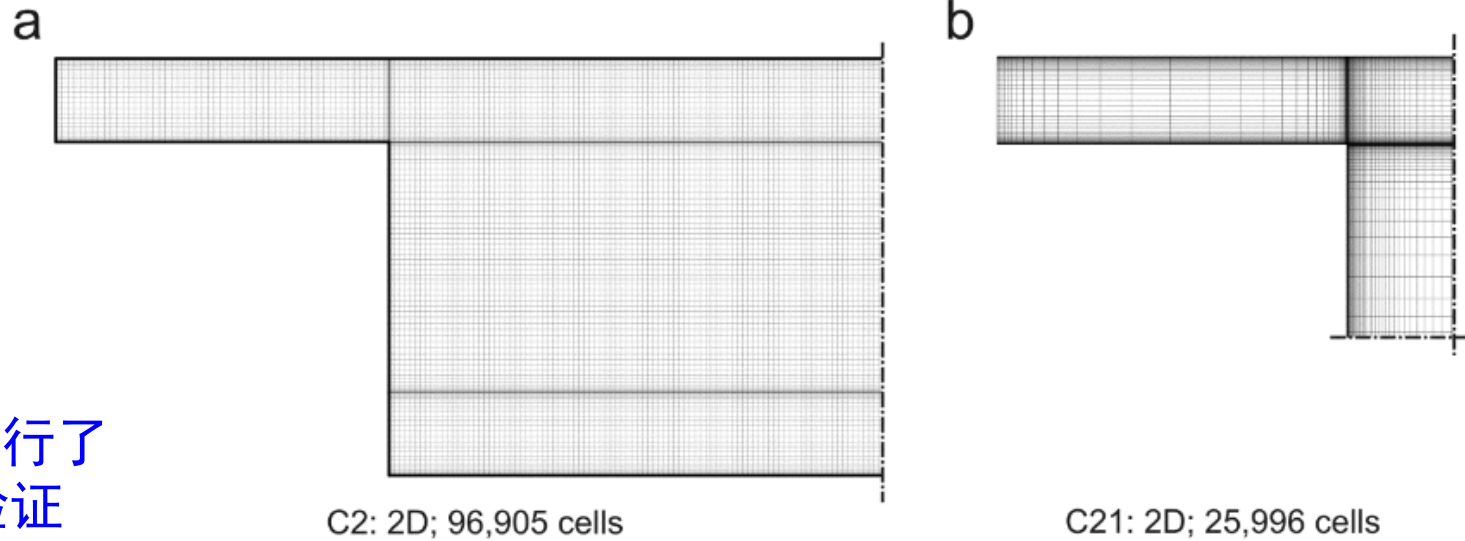

58%的算例进行了
网格独立性验证

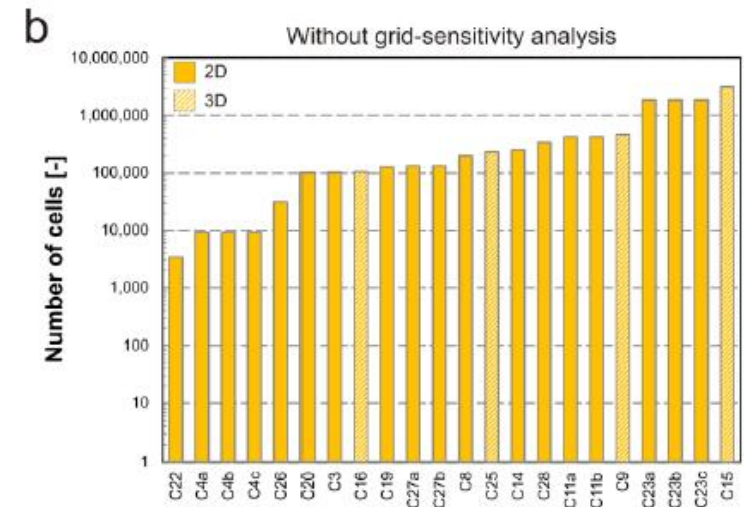
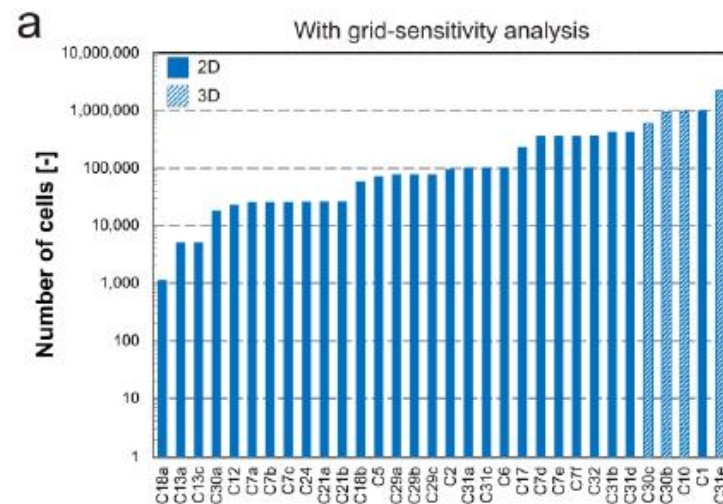

网格量悬殊

使用者帶來的不確定性

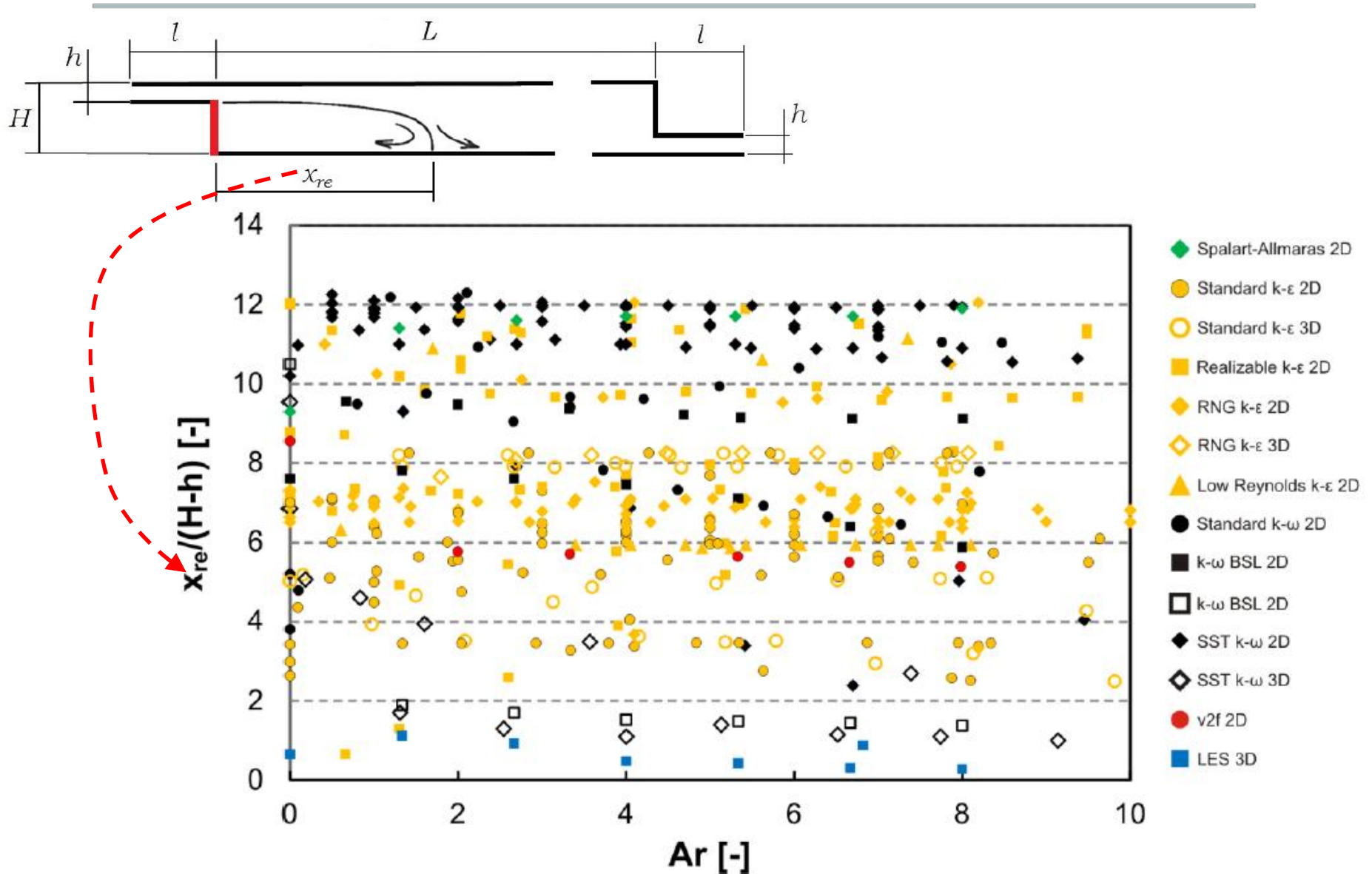

使用者带来的不确定性

1. 对模拟结果的综合影响

- ✓ 网格独立性
- ✓ 湍流模型
- ✓ 离散格式
- ✓ 收敛标准
- ✓ 用户经验
- ✓

2. 如何更好地确保CFD模拟的准确性？

- ✓ 对模拟结果进行验证的必要性
- ✓ 需要更多的基准数据提供参考
- ✓ 模拟导则的完善
- ✓ CFD使用人员的专业培训

CFD模拟标准与导则

基本设置导则——工业CFD应用一般性导则

1. **2000** ERCOFTAC special interest group on **quality and trust in industrial CFD** (Casey M, Wintergerste T, Innotec S)

European **R**esearch **C**ommunity on **F**low, **T**urbulence and **C**ombustion

给出最常用的RANS模拟一般性要求

不同的模拟场景的导则——存在共性、个性，发现一定的互通性，可多方面借鉴

1. **2002** CFD best practice guidelines for CFD code validation for **reactor safety applications** (Menter F, Hemstrom B)
2. **2004** Thematic Area 4: Best practice advice for civil construction and **HVAC** (Scaperdas A, Gilham S)
3. **2004** Thematic Area 5: Best practice advice for **environmental flows** (Bartzis J G, Vlachogiannis D, Sfetsos A)
4. **2005** Guidelines for applying commercial CFD software to **open channel flow** (Knight DW, Wright NG, Morvan HP)
5. **2007** Computational Fluid Dynamics in **Ventilation Design**: REHVA Guidebook No 10 (Nielsen PV, Allard F, Awbi HB, et al.)

欧洲COST:

1. **2004** Recommendations on the use of CFD in **wind engineering** (Franke J, Hirsch C, Jensen AG, et al.)
2. **2007** Best practice guideline for the CFD simulation of flows in the **urban environment** (Franke J, Hellsten A, Schlünzen H, et al.)
3. **2007** Model Evaluation Guidance and Protocol Document COST Action 732 (Britter R., Schatzmann M.)



日本AIJ:

1. **2007** Cooperative project for CFD prediction of **pedestrian wind environment** in the Architectural Institute of Japan (Yoshie R, Mochida A, Tominaga Y, et al.)
2. **2008** AIJ guidelines for practical applications of CFD to **pedestrian wind environment around buildings** (Tominaga Y, Mochida A, Yoshie R, et al.)
3. **2008** AIJ guide for numerical prediction of **wind loads** on buildings (Tamura T, Nozawa K, Kondo K.)



目录

1. 气流模拟简介
2. 人工环境领域CFD模拟的特殊问题
3. 模拟结果的质量控制
4. 案例介绍
5. 总结

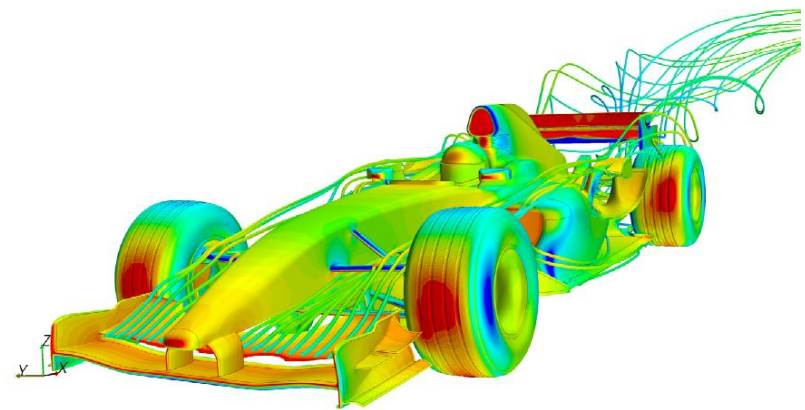

隧道活塞风

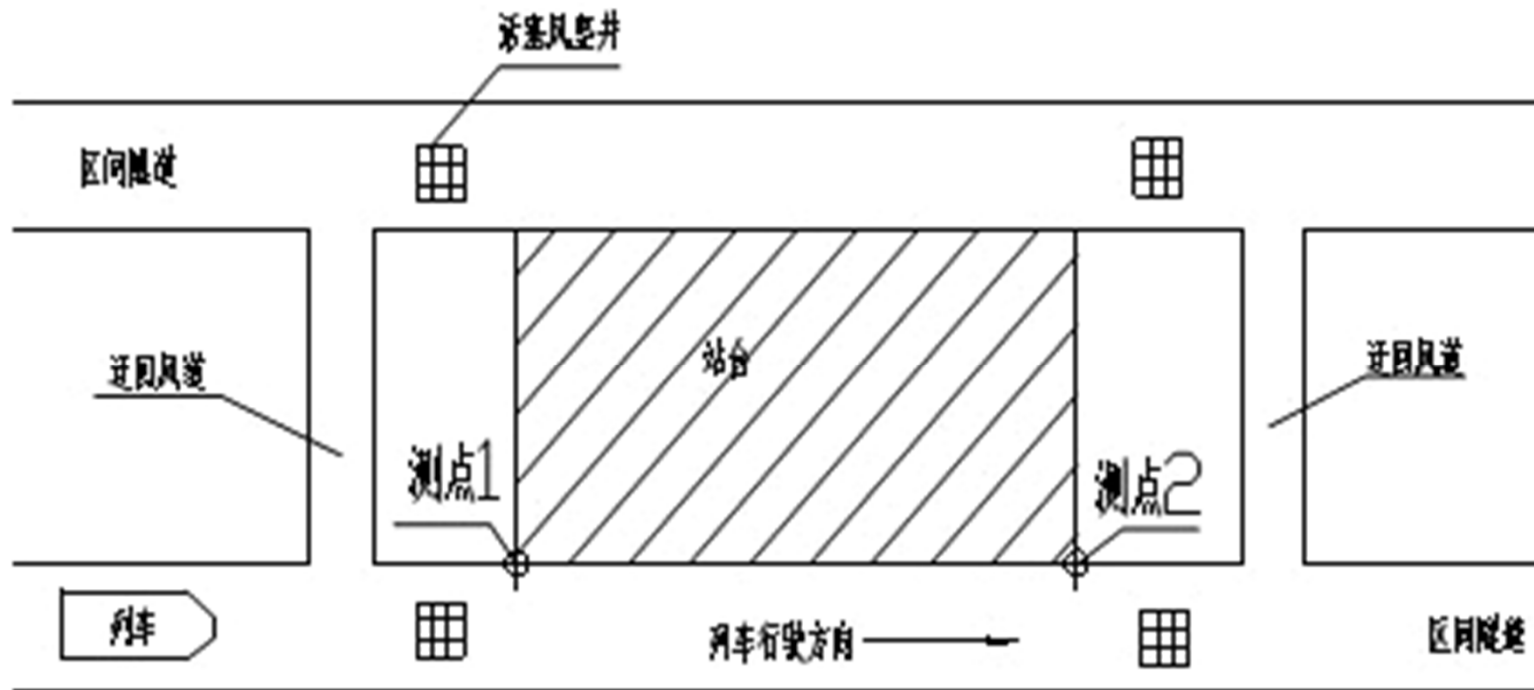

隧道活塞风

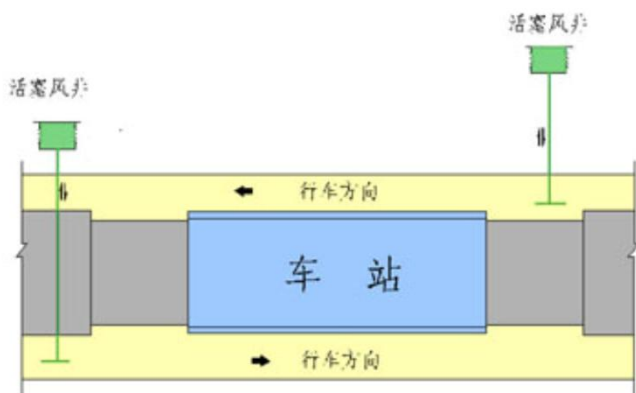

进站端设活塞风井(工况一)

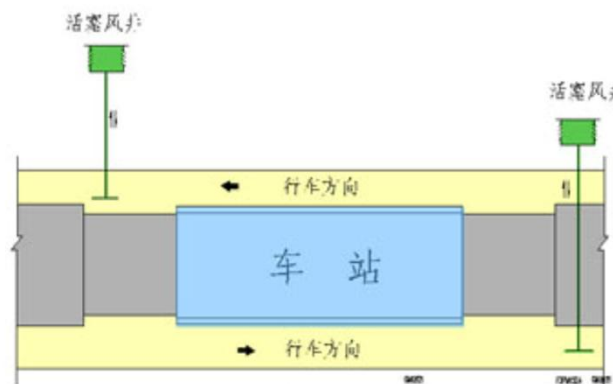

离站端设活塞风井(工况二)

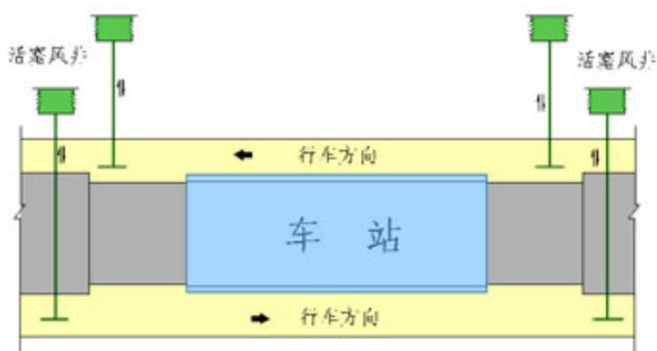

双活塞风井(工况三)

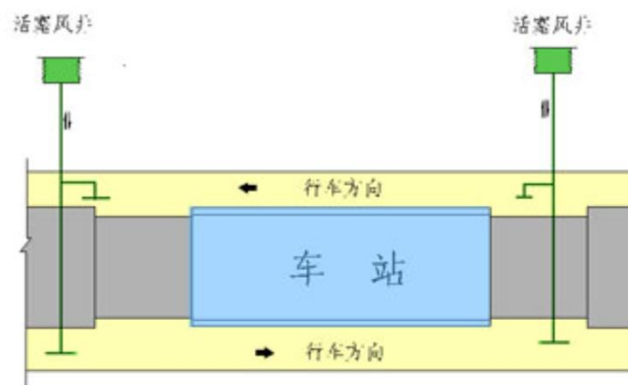

共用单活塞风井(工况四)

隧道活塞风

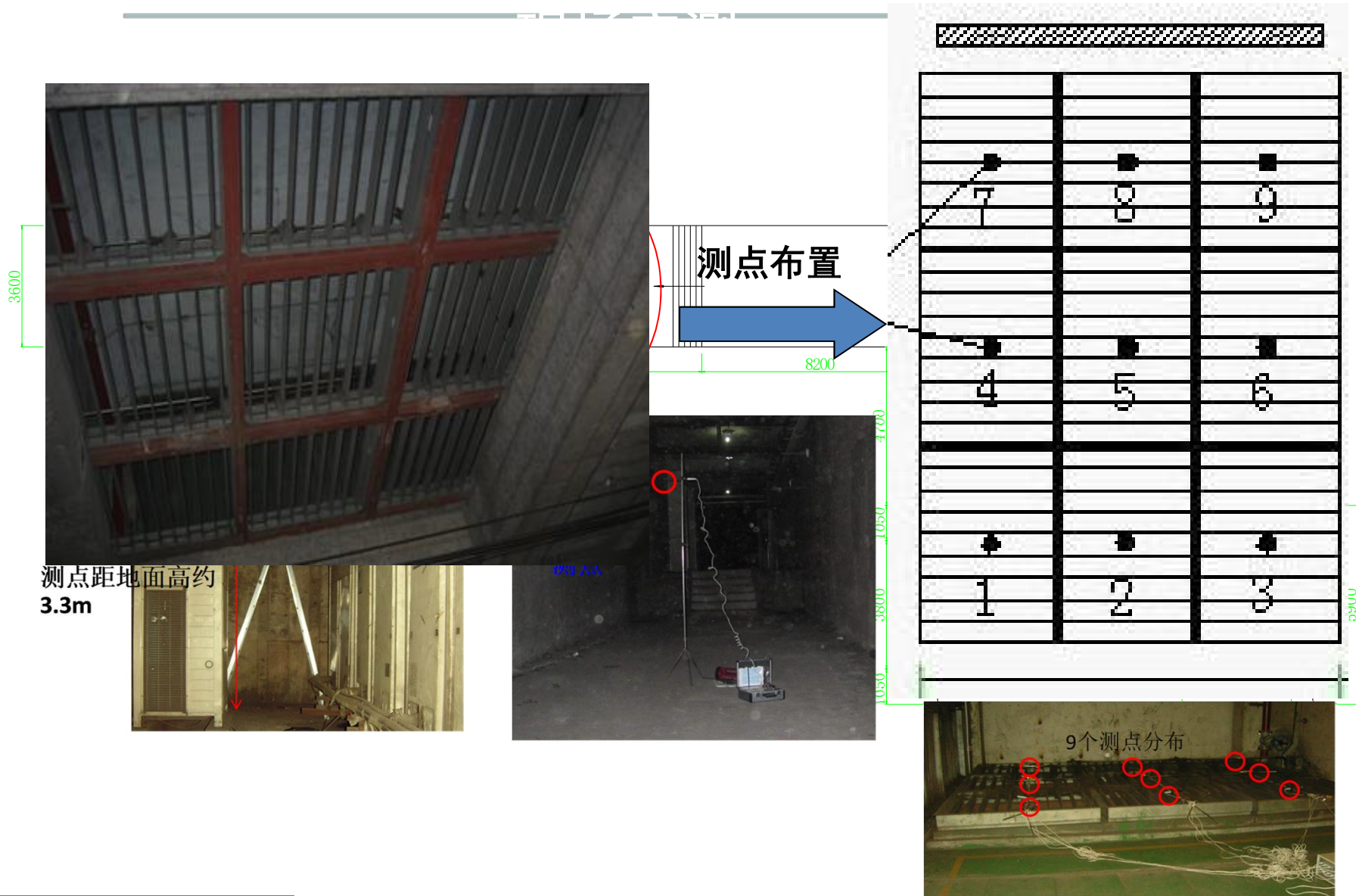

隧道活塞风

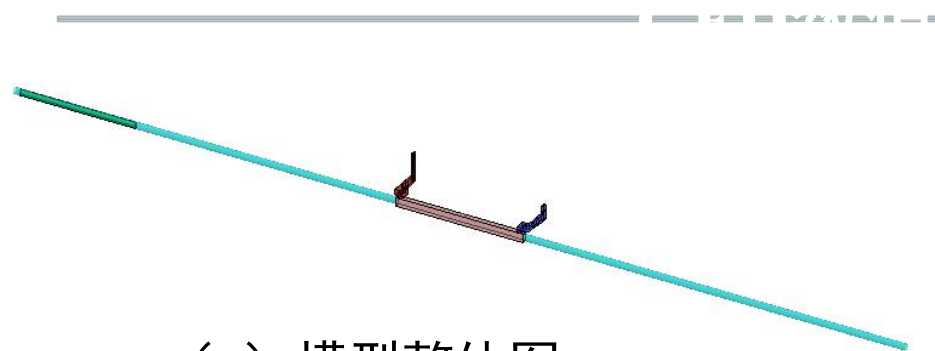

(a) 模型整体图

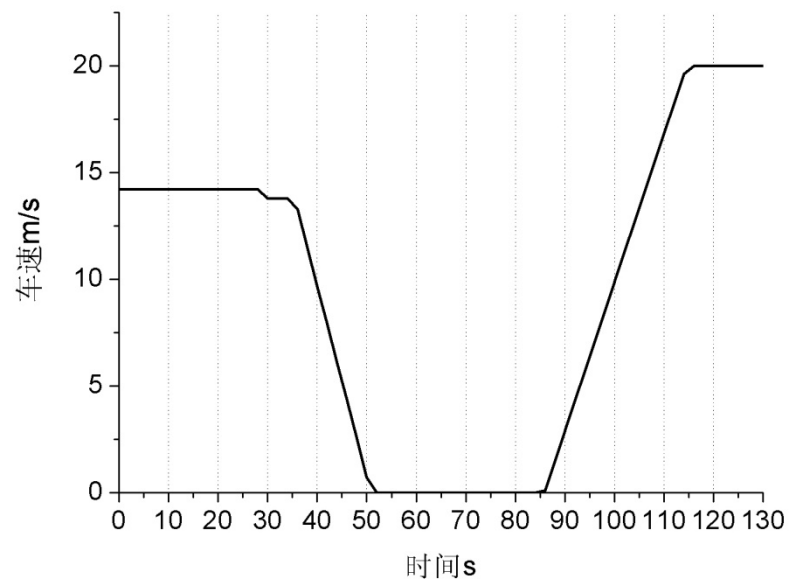

几何模型示意图

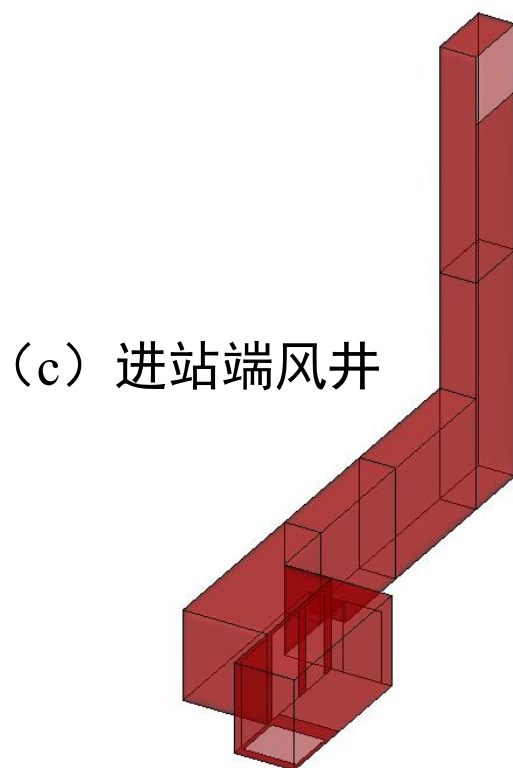

(c) 进站端风井

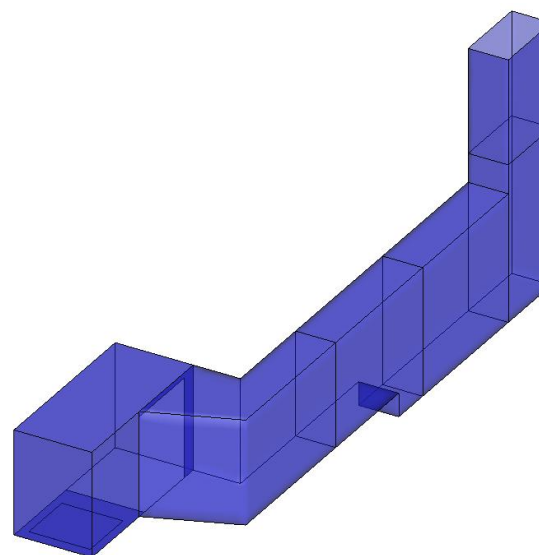

(d) 出站端风井

隧道活塞风

15s时（列车匀速进站）列车的行驶位置、进站端活塞风井的压力分布及流动状态

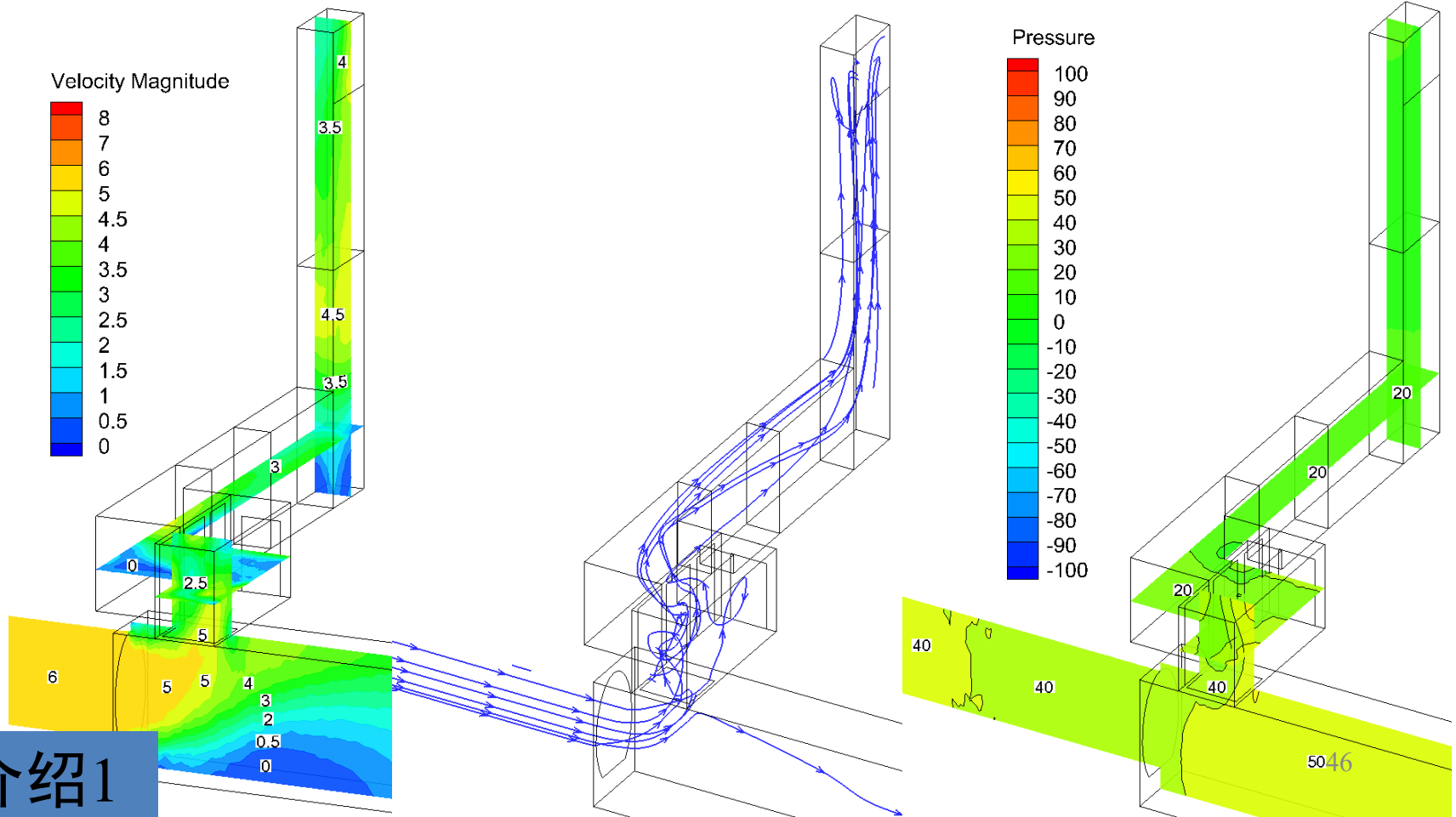
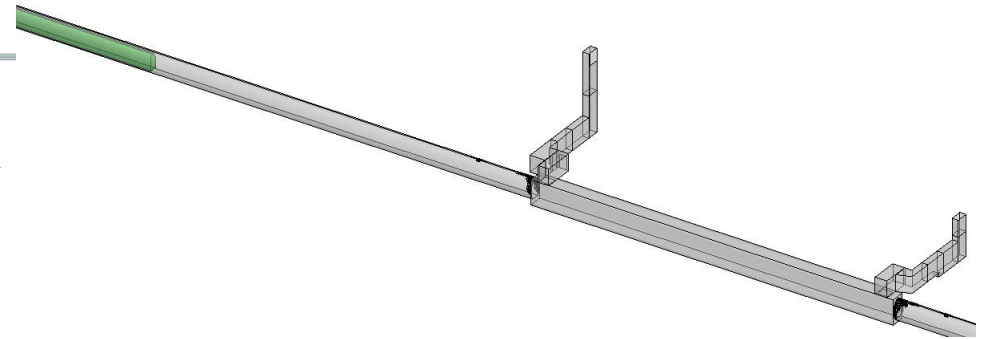

案例介绍1

隧道活塞风

28s时（列车开始减速时刻）列车的行驶位置、进站端活塞风井的压力分布及流动状态

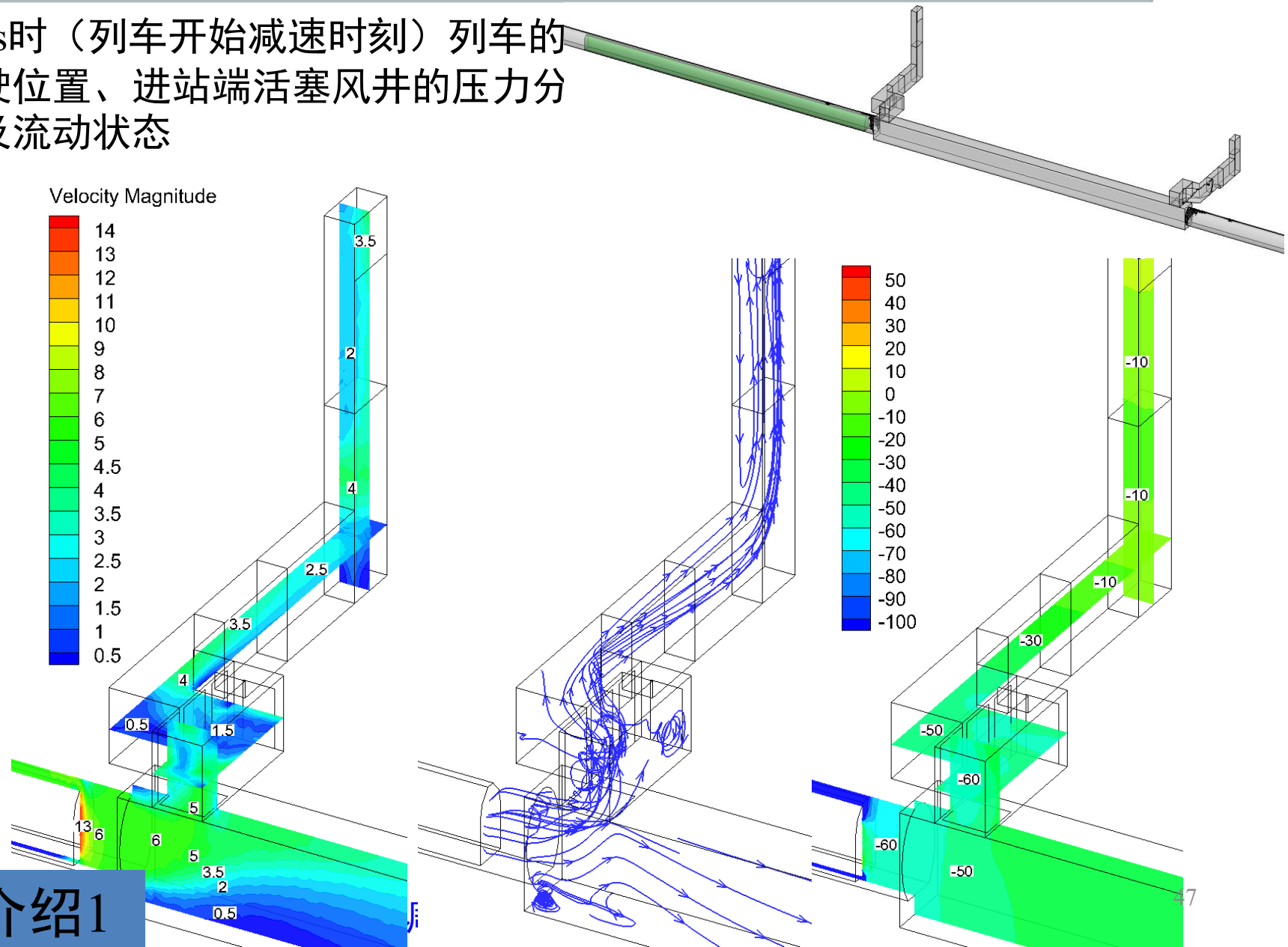

案例介绍1

隧道活塞风

52s时（列车刚刚停车时刻）列车的行驶位置、进站端活塞风井的压力分布及流动状态

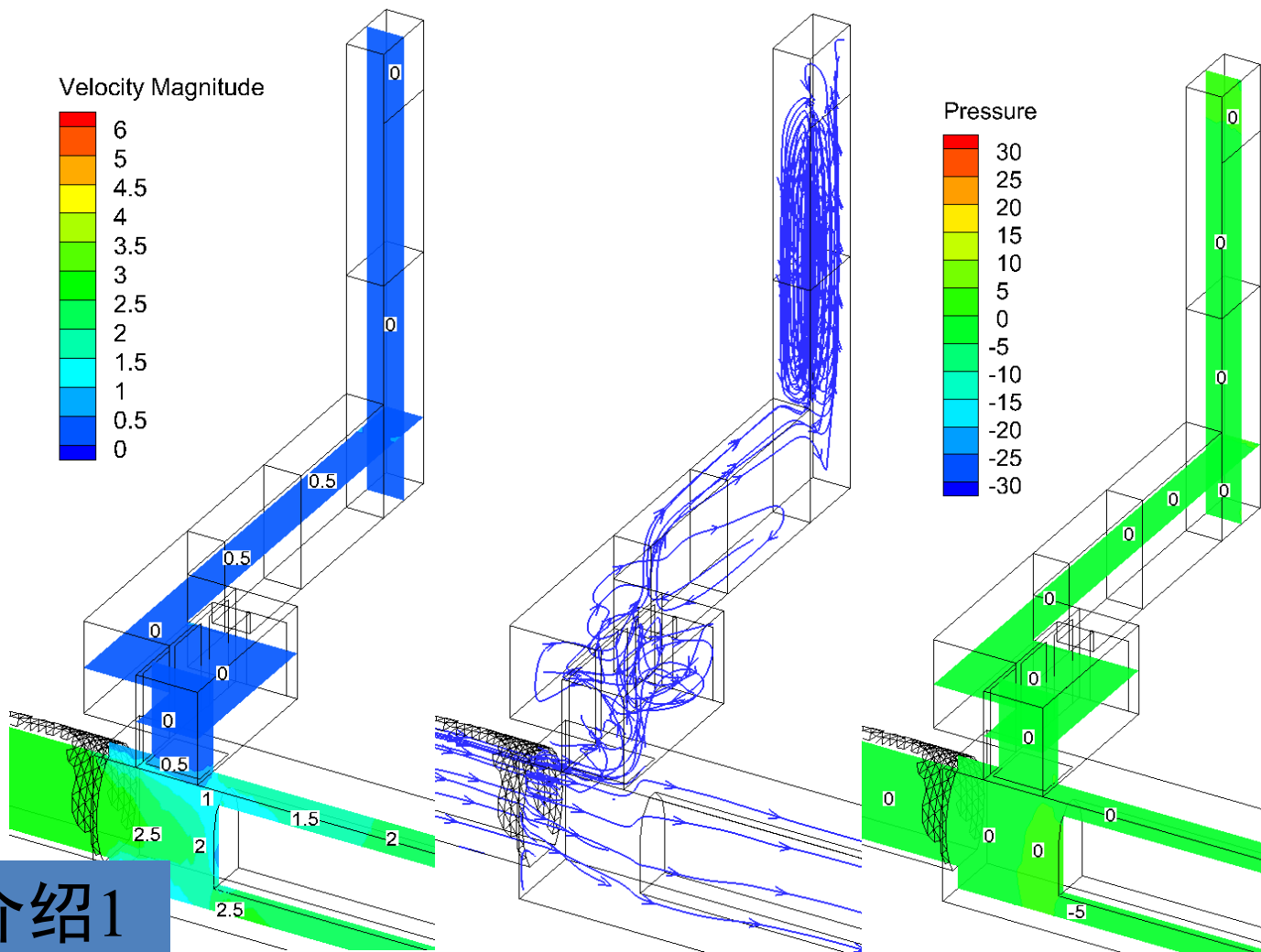
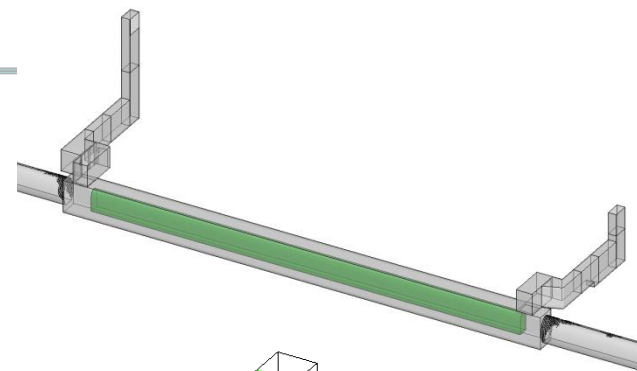

案例介绍1

隧道活塞风

65s时（列车停站）列车的行驶位置、进站端活塞风井的压力分布及流动状态

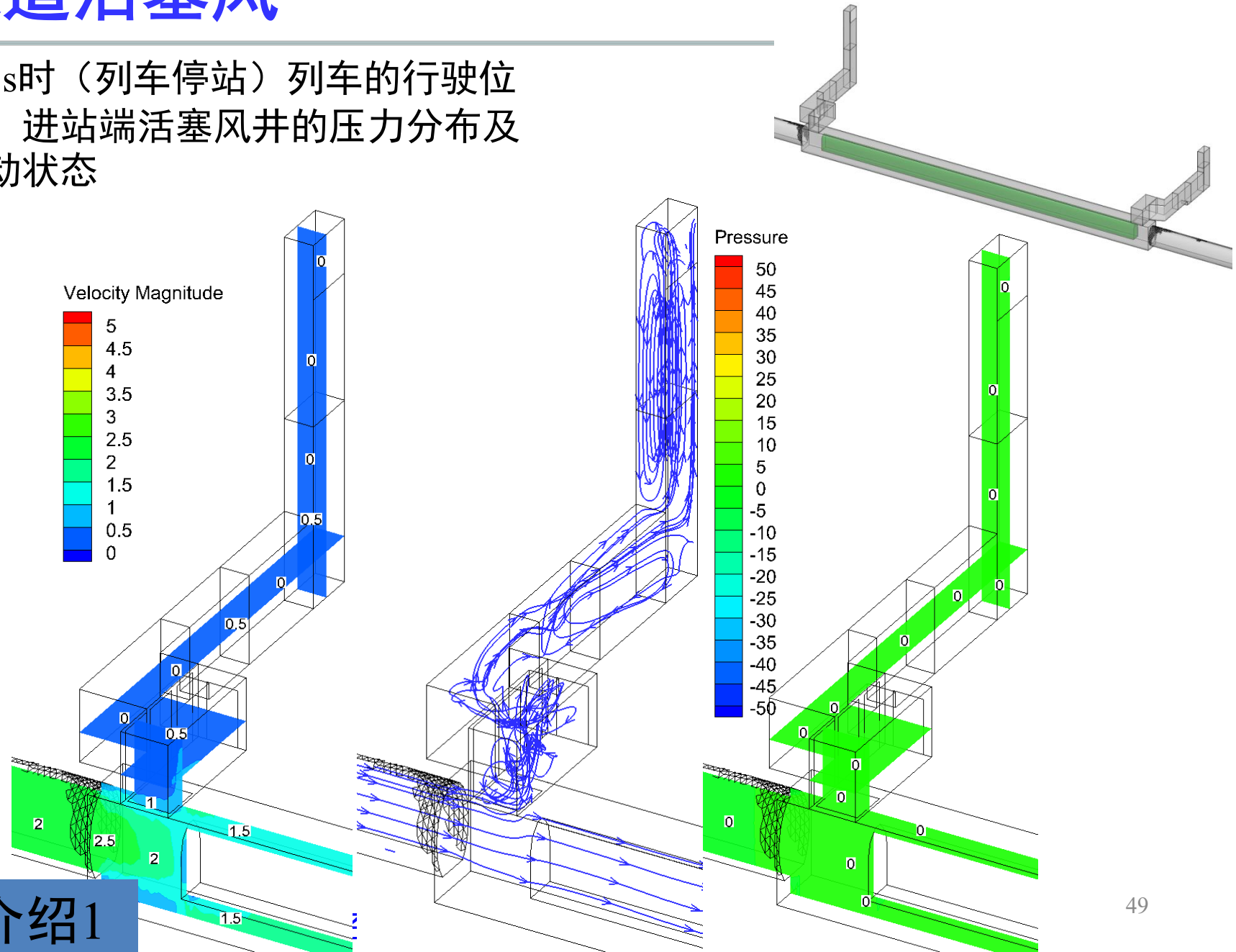

案例介绍1

隧道活塞风

85s时（列车启动时刻）列车的行驶位置、进站端活塞风井的压力分布及流动状态

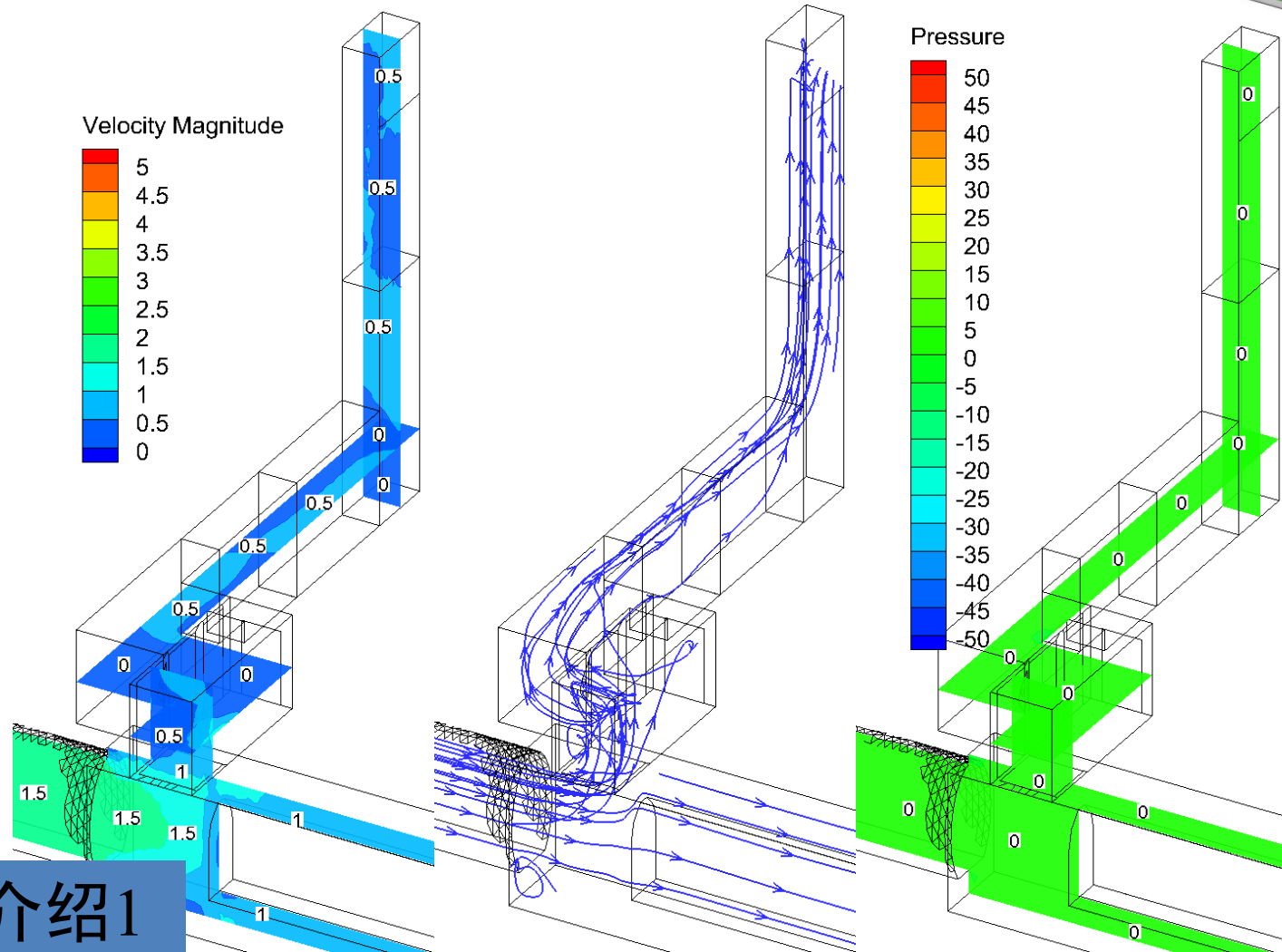
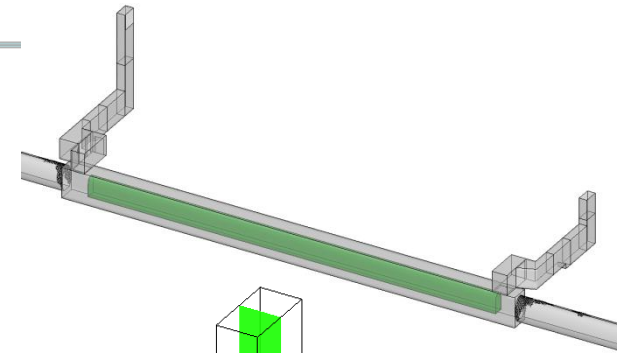

案例介绍1

隧道活塞风

120s时（列车匀速离站）列车的行驶位置、进站端活塞风井的压力分布及流动状态

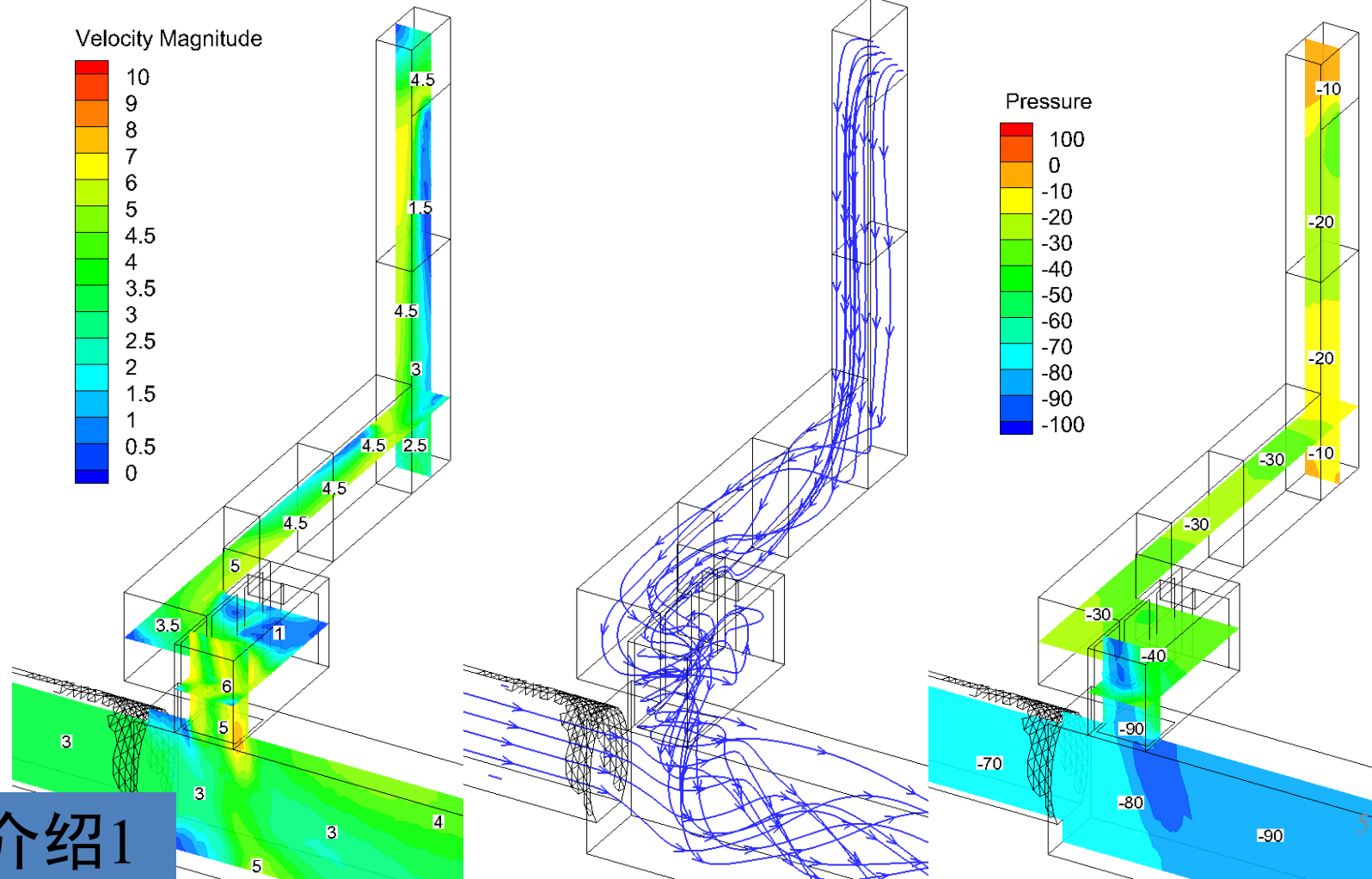
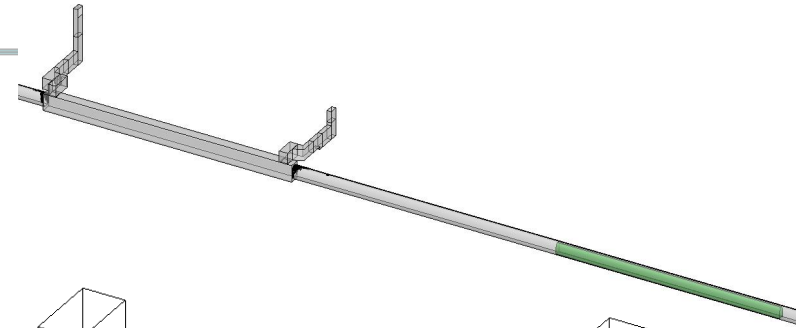

案例介绍1

隧道活塞风

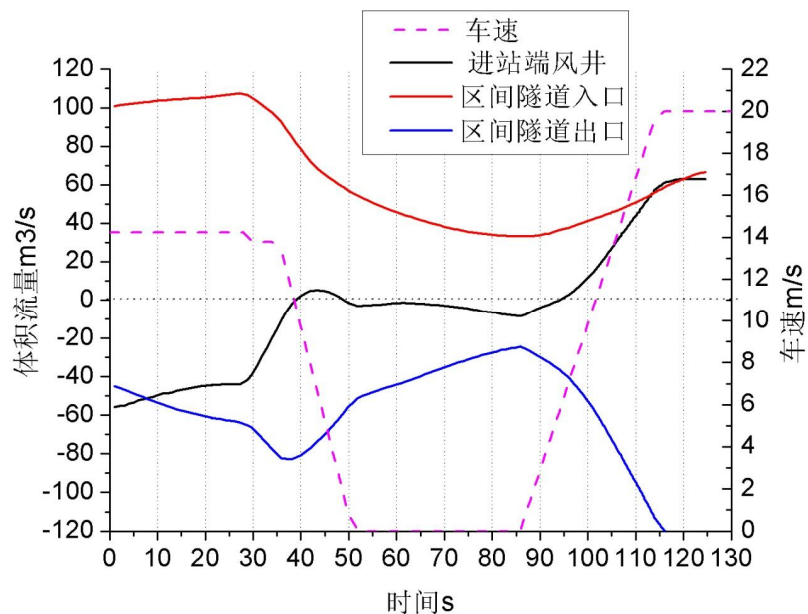
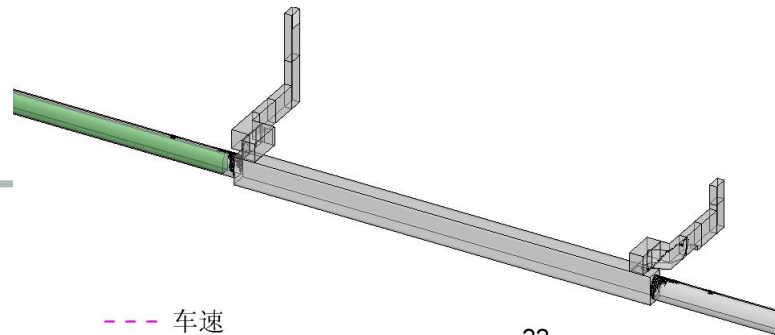

正值为进风，负值为排风

进站端风井总进排风量

风井体积(m ³)	1340
排风量(m ³)	1712
进风量(m ³)	1334

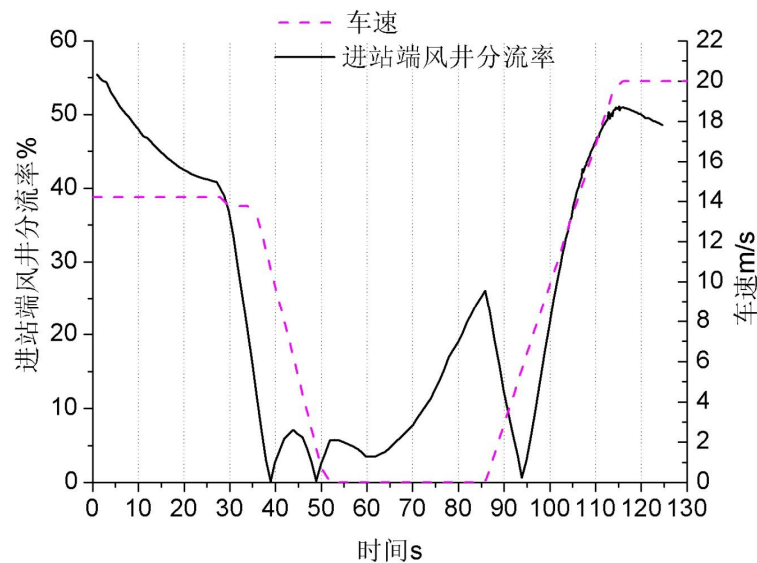

◆列车匀速进站和匀速离站时，活塞风井内流量占总流量的比值较大，也就是说**风井的分流作用明显**；

◆列车停站时，区域总风量降低，风井分流作用也在降低。

隧道活塞风—总结

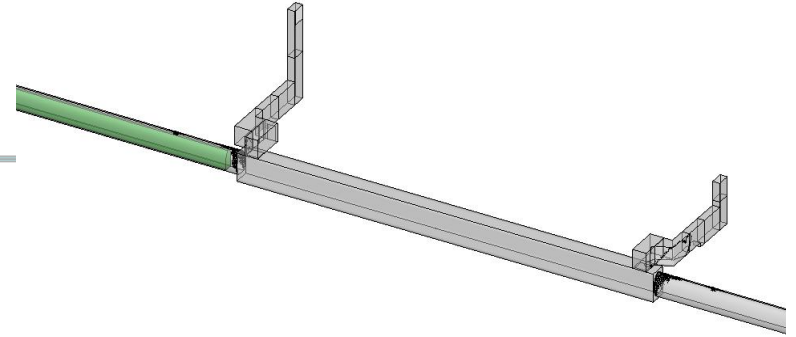

- a) 采用**双风井时换气效果明显优于单风井**，且采用**双风井的总换气量比单独采用进站端风井和出站端风井的风量总和还要大**。
- b) 采用双风井时，进站端风井的换气量比单独使用该风井时小，**出站端风井的开启对进站端风井内的活塞风有抑制作用**。
- c) 采用双风井时，出站端风井的换气量比单独使用该风井时大，**进站端风井的开启对出站端风井内的活塞风有增强作用**。
- d) 采用单风井时，**风井位置不同时，换气效果也不同**。进站端风井的作用强于出站端，无论进站端的进风量还是排风量均比出站端要大。
- e) 进站端风井和出站端风井在单独使用时，前者的换气量大；而在共同使用时，后者的换气量大。

高层建筑污染物跨户传播

CFD

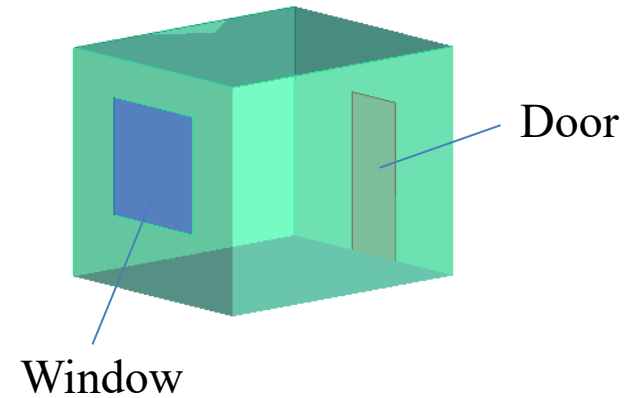
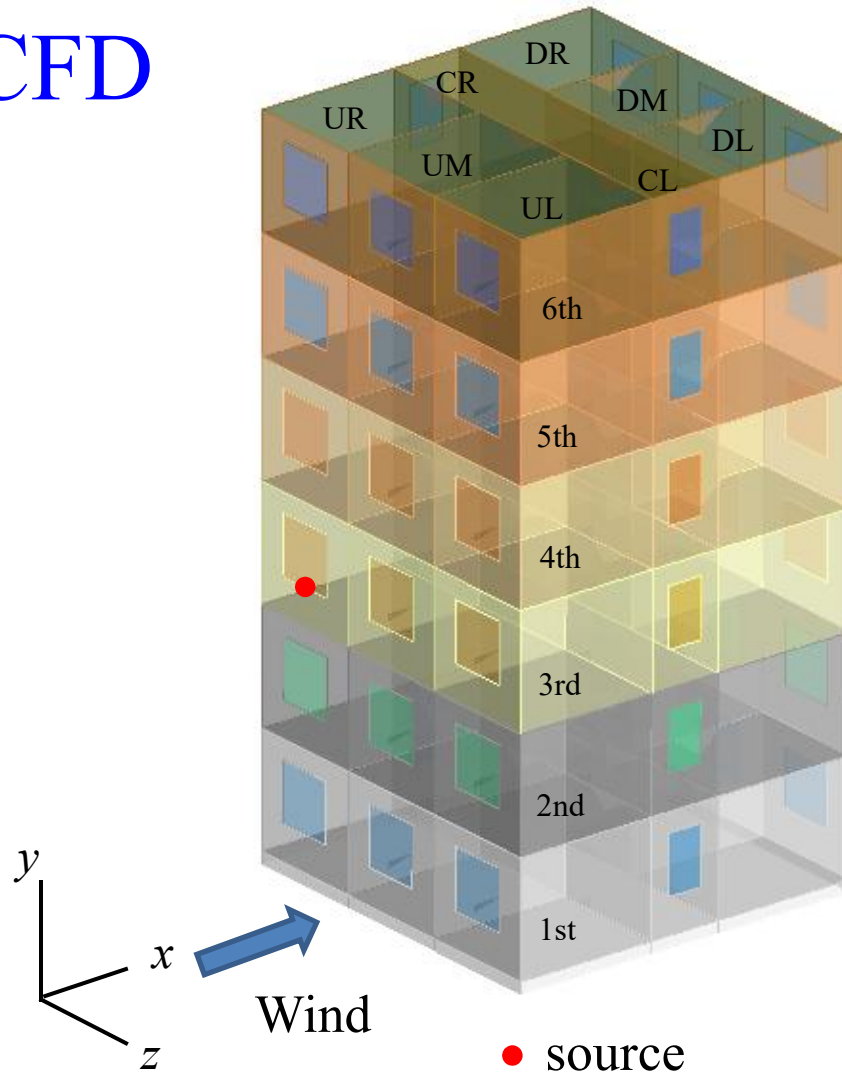

工况一：单侧自然通风

工况二：穿堂风

高层建筑污染物跨户传播



高层建筑污染物跨户传播

模型验证: 与风洞实验对比

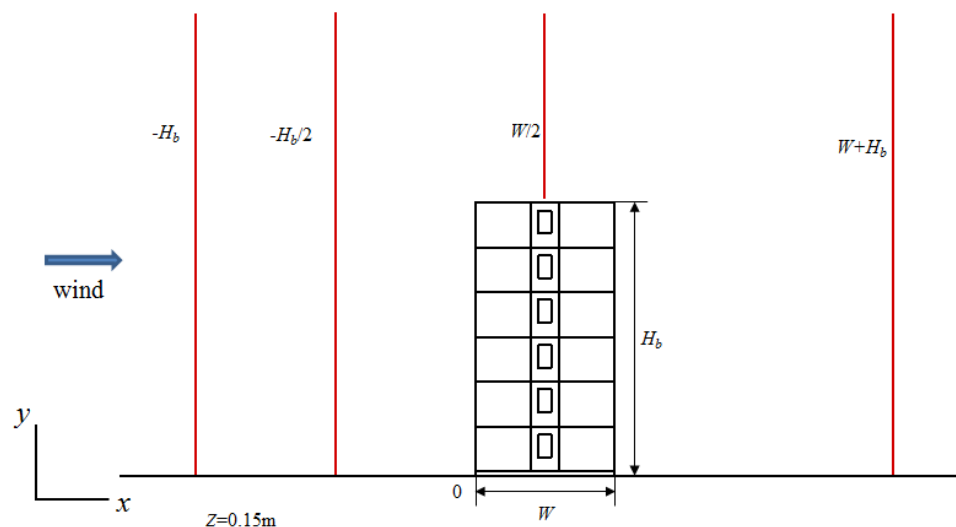

整体而言，除了在建筑屋顶处和尾涡外，RNG $k-\varepsilon$ 模型可以反映出和风洞实验相吻合的流场。

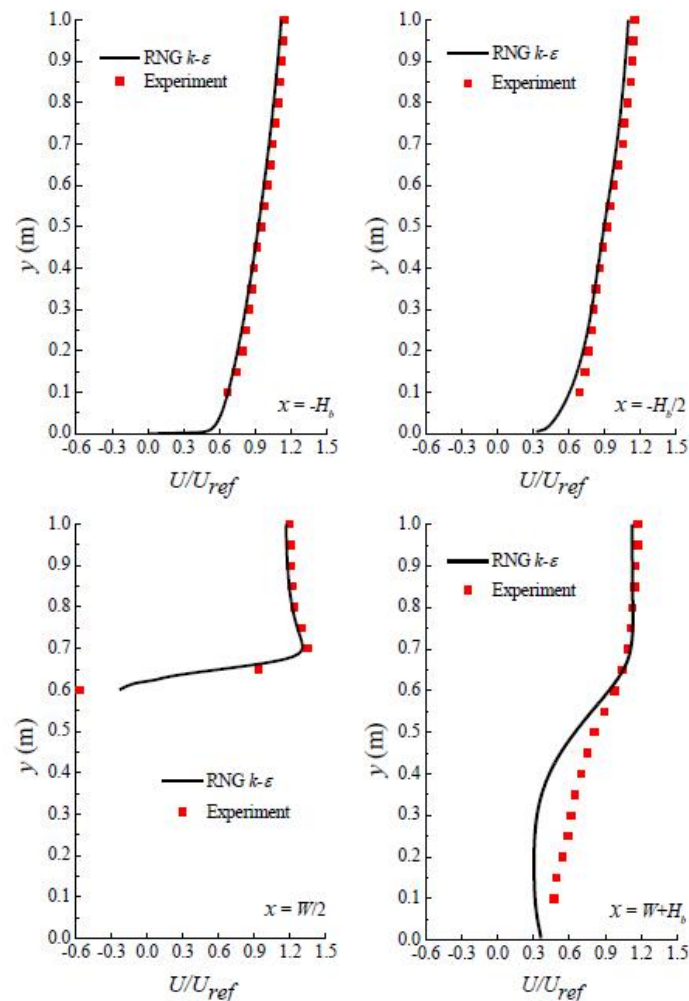

高层建筑污染物跨户传播

工况一：单侧自然通风

- 迎风面高层→低层
- 迎风面→侧面→背风面

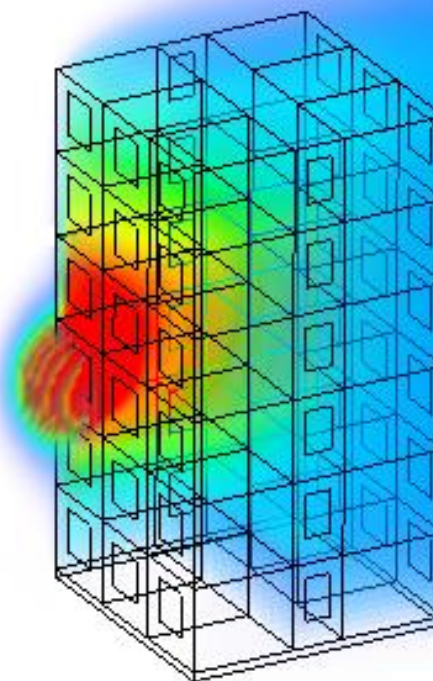
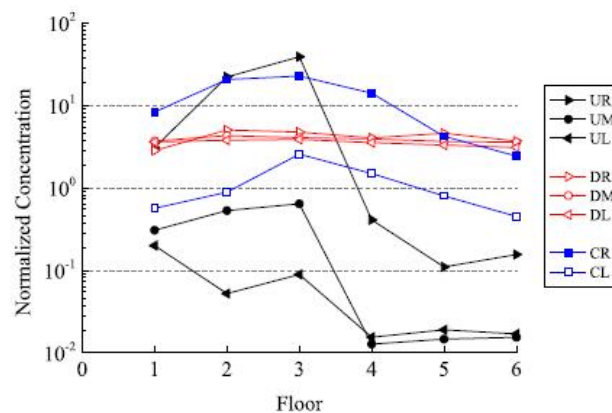
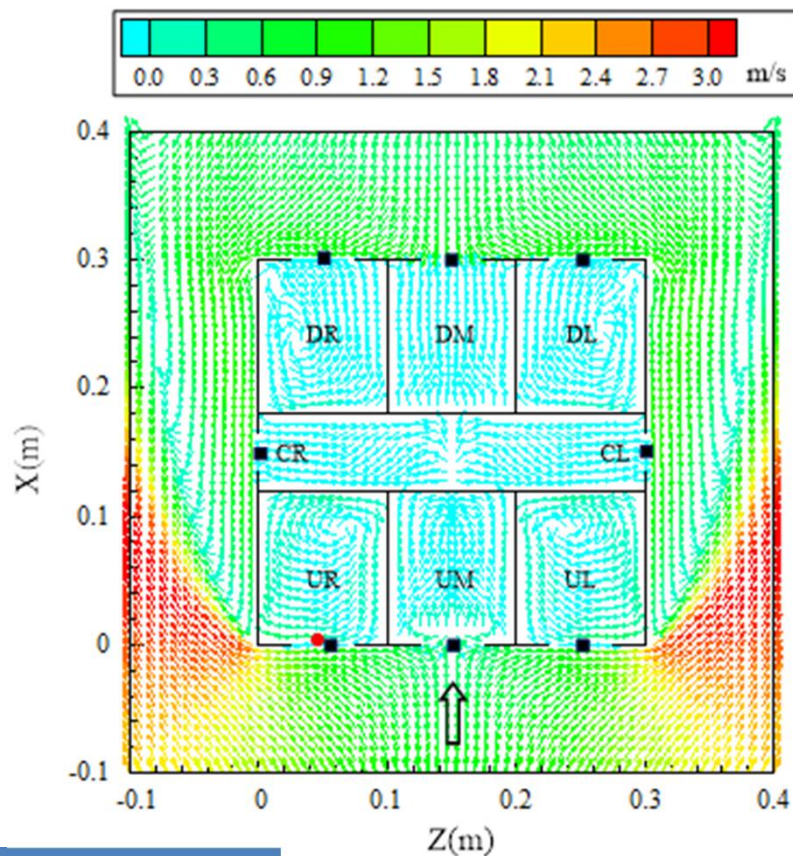

高层建筑污染物跨户传播

工况二：穿堂风

- 迎风面→建筑内部→背风面

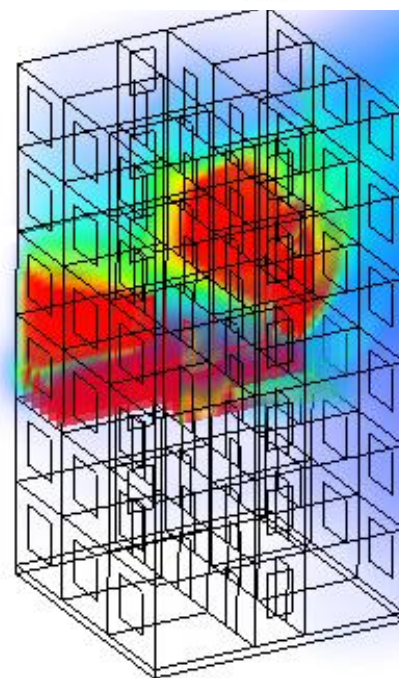
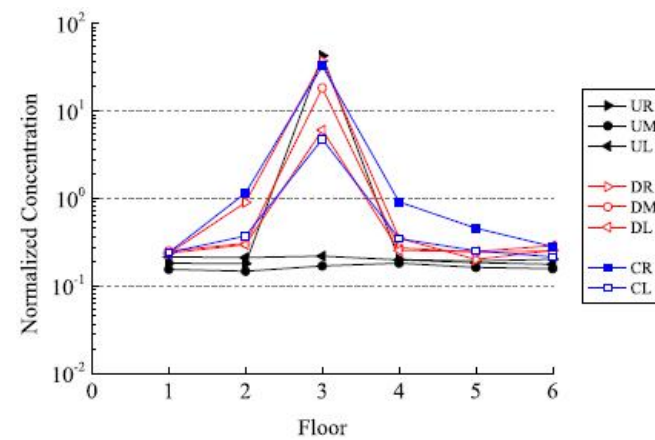
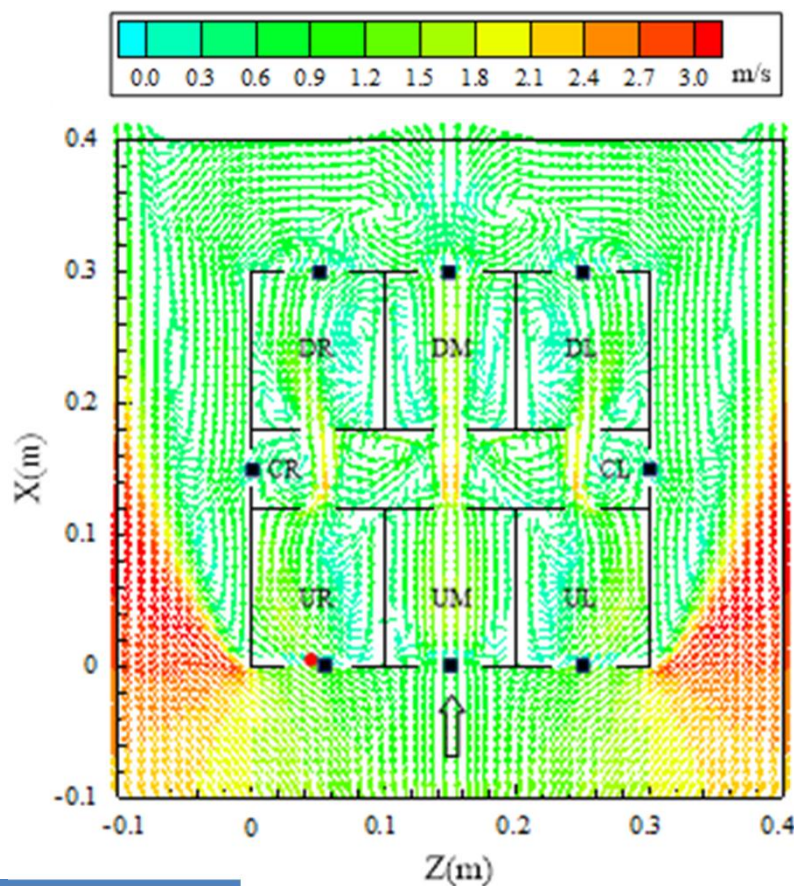

高层建筑污染物跨户传播

CFD小结

- a) RNG $k-\varepsilon$ 湍流模型可以定性给出可信度较高的可视化流场，进一步给出直观的污染物浓度分布情况，反映污染物的传播趋势。
- b) RNG $k-\varepsilon$ 湍流模型抹去了涡流在时间上的脉动值，进而无法捕捉污染物的瞬态波动情况，这是导致浓度分布的模拟值与风洞实验值有出入的重要原因之一。
- c) 单侧自然通风的建筑中，迎风侧某单元释放的污染物可发生垂直方向的传播以及自迎风面至背风面垂直和水平方向的传播。
- d) 穿堂风抑制了迎风侧释放的污染物在垂直方向上的传播，但增强了自迎风面穿过建筑至背风面水平方向的传播效应。

高层建筑污染物跨户传播

CONTAM多区模拟

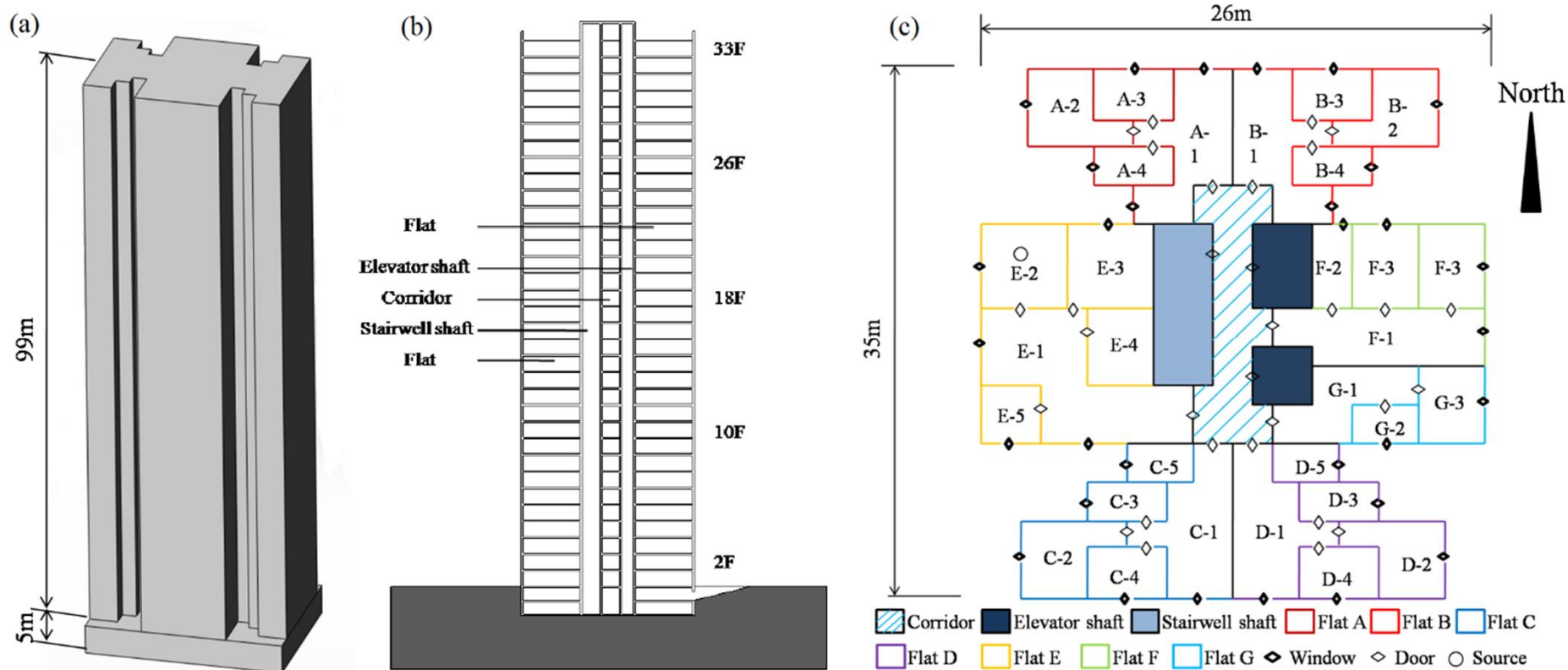

- ✓ 建筑各个位置的渗透系数是多区模拟最重要的边界条件之一，会对模拟的准确性产生重要影响。

高层建筑污染物跨户传播

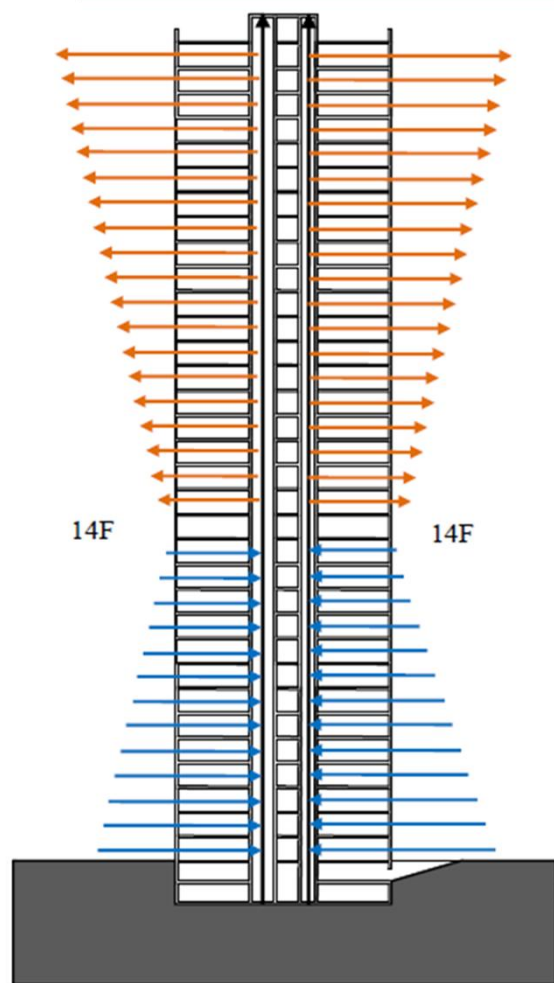

烟囱效应下建筑内部空气流动方向
NPL 14层

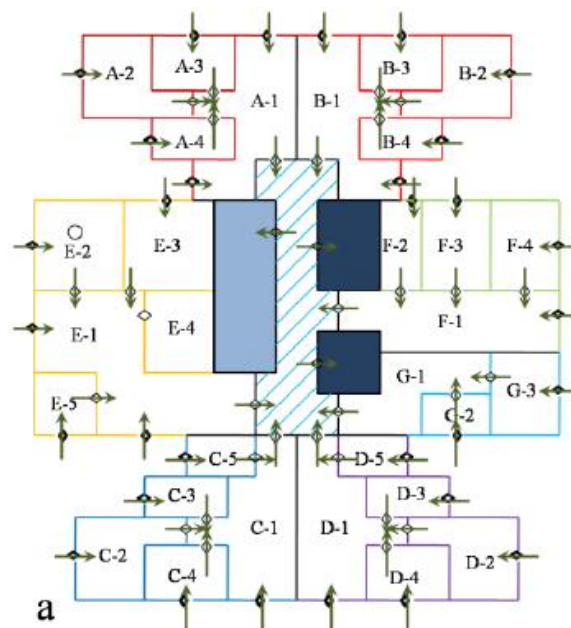

a. 压力中和面以下
楼层内气流方向

b. 压力中和面以上
楼层内气流方向

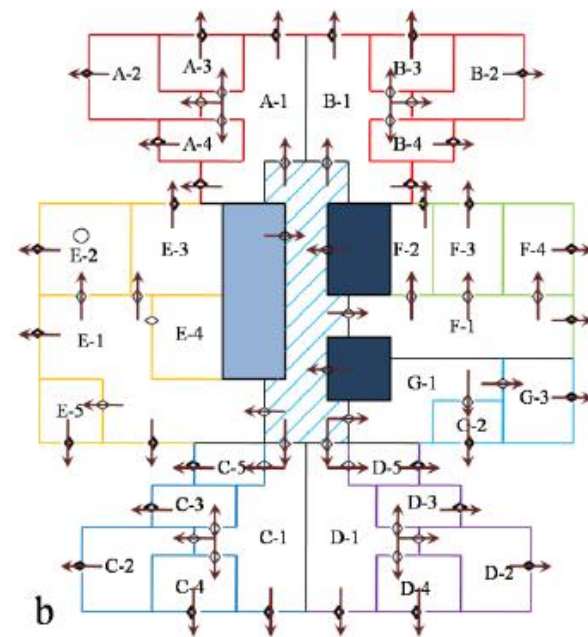

高层建筑污染物跨户传播

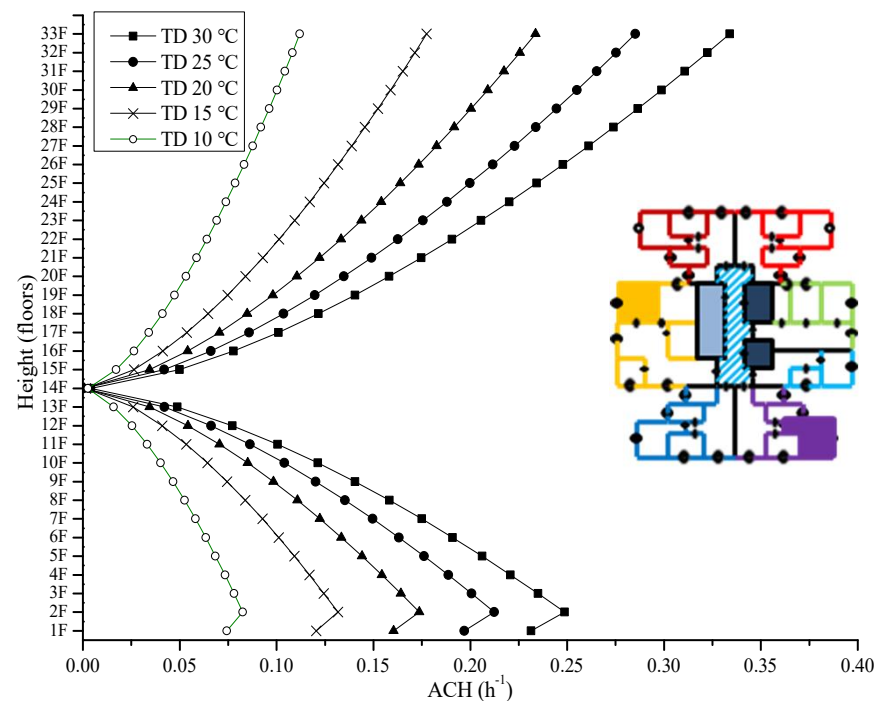
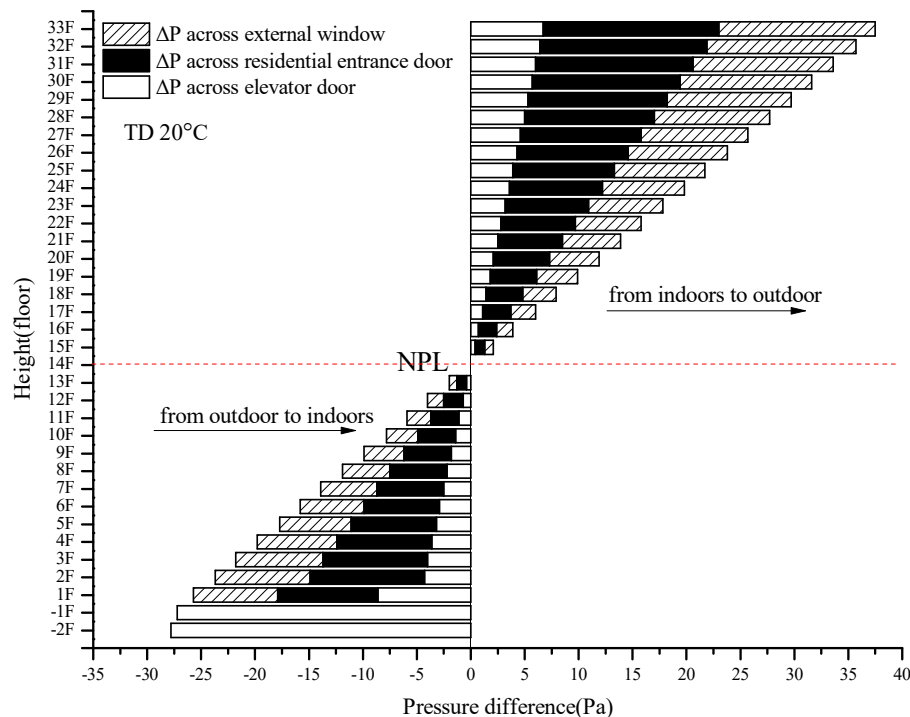

- ✓ 建筑各个不同部位的压差在竖直高度方向上线性增长。建筑各层房间的换气次数因压差的线性变化在高度方向上呈现相似的变化趋势，且当门窗都关闭时，各层室内的换气次数均小于0.5/h。

高层建筑污染物跨户传播

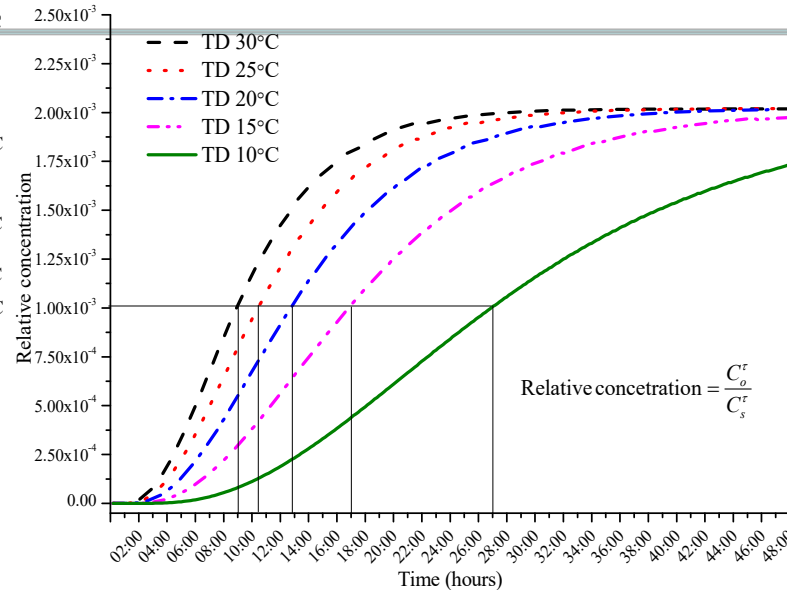
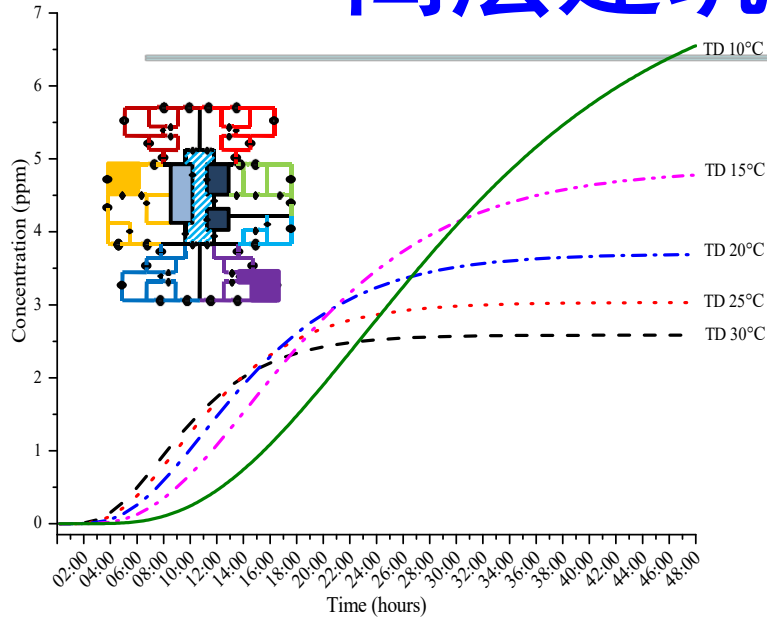

✓室内外温差的增大，意味着更快的污染物传播速度和更低的污染物稳定浓度，污染物浓度低3~4个数量级。

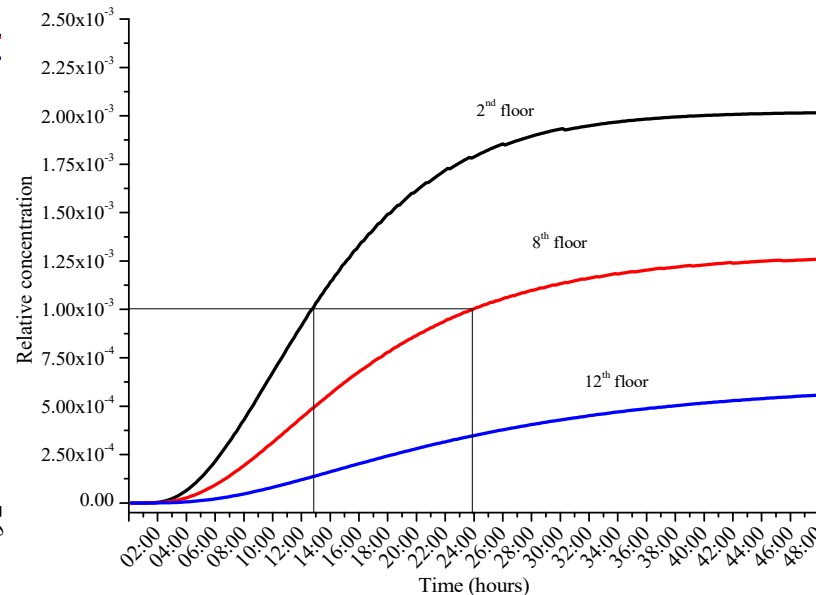
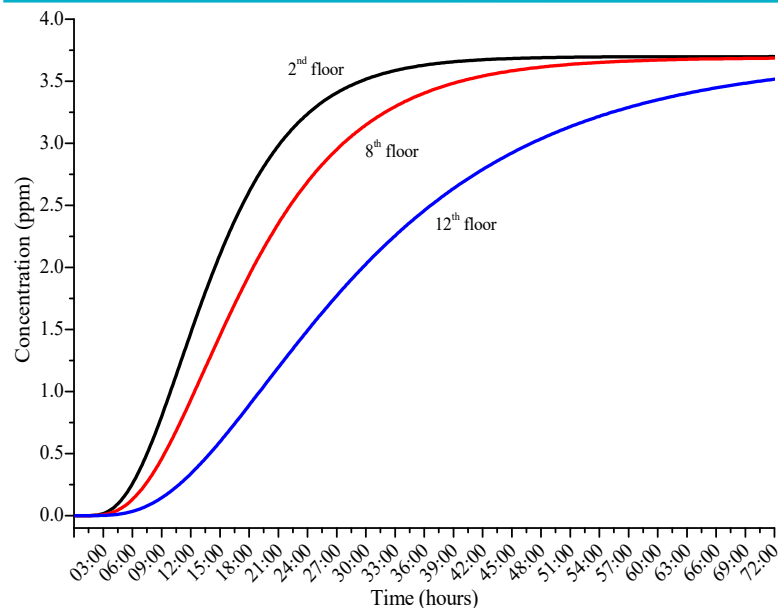

✓污染源从2楼上升到12楼后，目标房间内的污染物相对浓度降低了1个数量级。

总结

1. 更快

—快速流体力学，实时模拟（FFD）

2. 更准

—新的湍流模型，大涡模拟（LES）

3. 更强

—多物理场耦合模拟（COMSOL）

—多尺度模拟（multi-scale）

—更加专业化(融合本专业的数据库、设备库、评价指标等等)

建筑气流模拟及应用

谢谢大家!

高乃平

同济大学

gaonaiping@tongji.edu.cn